



## VLT® AQUA Drive

*The ultimate solution for Water, Wastewater & Irrigation*

# The VLT® AQUA Drive is innovative

– Reduces system, installation and operating costs



**Danfoss VLT® AQUA Drive is dedicated to water and wastewater applications. With a wide range of powerful standard and optional features, the VLT® AQUA Drive provides the lowest overall cost of ownership for water and wastewater applications.**

### **Save energy**

The VLT® AQUA Drive offers considerable energy savings:

- VLT® efficiency (up to 98%)
- Sleep Mode
- Automatic Energy Optimisation AEO: Typically 3-5% energy saving
- Flow compensation, lowering pressure set point and thus energy consumption under low flow conditions

### **Save space**

The compact design of the VLT® AQUA Drive makes it easily fit in even small installation spaces.

- Built-in DC coils for harmonic suppression. No need for external AC coils
- Optional, built-in RFI filters in the whole power range
- Intelligent cooling concept reduces need for installation space.

### **Protects the environment**

*The growing need for clean water and energy conservation is rapidly increasing the pressure on global fresh water resources, wastewater treatment, recycling and power generation. VLT® AQUA Drive is designed to enhance system operation, protect equipment, reduce chemical consumption and water loss, while providing significant energy savings. VLT® AQUA Drive is the ultimate solution for all water, wastewater and recycling processes.*

### **Save cost and protect your system**

with a series of pump-specific features:

- Cascade controller
- Dry run detection
- End of curve detection
- Motor alternation

- 2-step ramps (initial and final ramp)
- Check valve protection
- Safe stop
- Low flow detection
- Pipe fill mode
- Sleep mode
- Real-time clock
- Password protection
- Overload trip protection
- Smart Logic Controller

Can be set to either variable or constant torque operation in the full speed range.

**Save panel space**

NEMA/UL Type 12 (IP 54/55) enclosure solution is available in the whole power range.

Up to 90 kW, the VLT® AQUA Drive can even be delivered in an IP 66 version.

**Save time**

VLT® AQUA Drive is designed with the installer and operator in mind in order to save time on installation, commissioning and maintenance.

- Intuitive user interface with the award-winning control panel (LCP)
- Same user interface for the full power range
- Modular VLT® design enables fast installation of options
- Auto tuning of PI controllers
- Robust design and efficient monitoring make the VLT® AQUA Drive maintenance free.

**Dedicated to water and wastewater**

Danfoss VLT Drives' unequalled experience was used to make the VLT® AQUA Drive the perfect match for AC motor driven applications in modern water and wastewater systems – also for retrofitting.

Water and Wastewater is a global business area for Danfoss VLT Drives and you will find our dedicated sales and service staff all over the world 24 hours a day.



**Ideal Energy Consumption at Varying Speed**

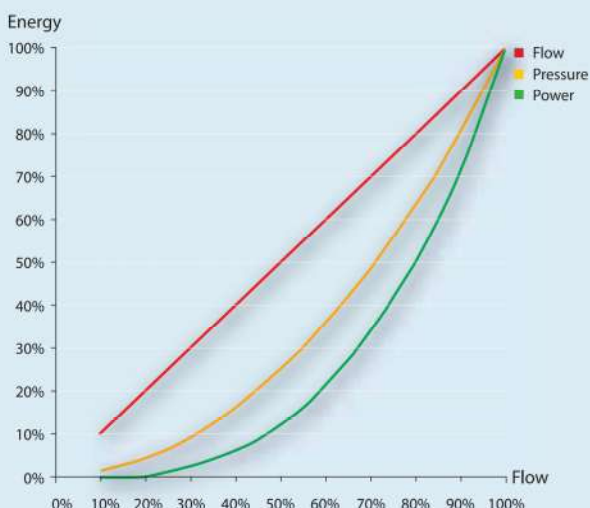

Energy savings using a VLT® AQUA Drive are achieved even with a modest reduction in speed.

**Distribution System Water Losses**

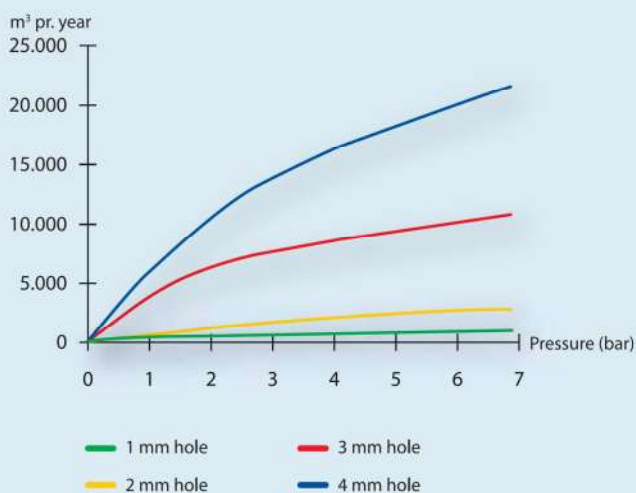

Reducing water losses by lowering system pressure becomes increasingly effective as the size of line breaks increase.

# Water and Wastewater processes

– Improved control using less energy

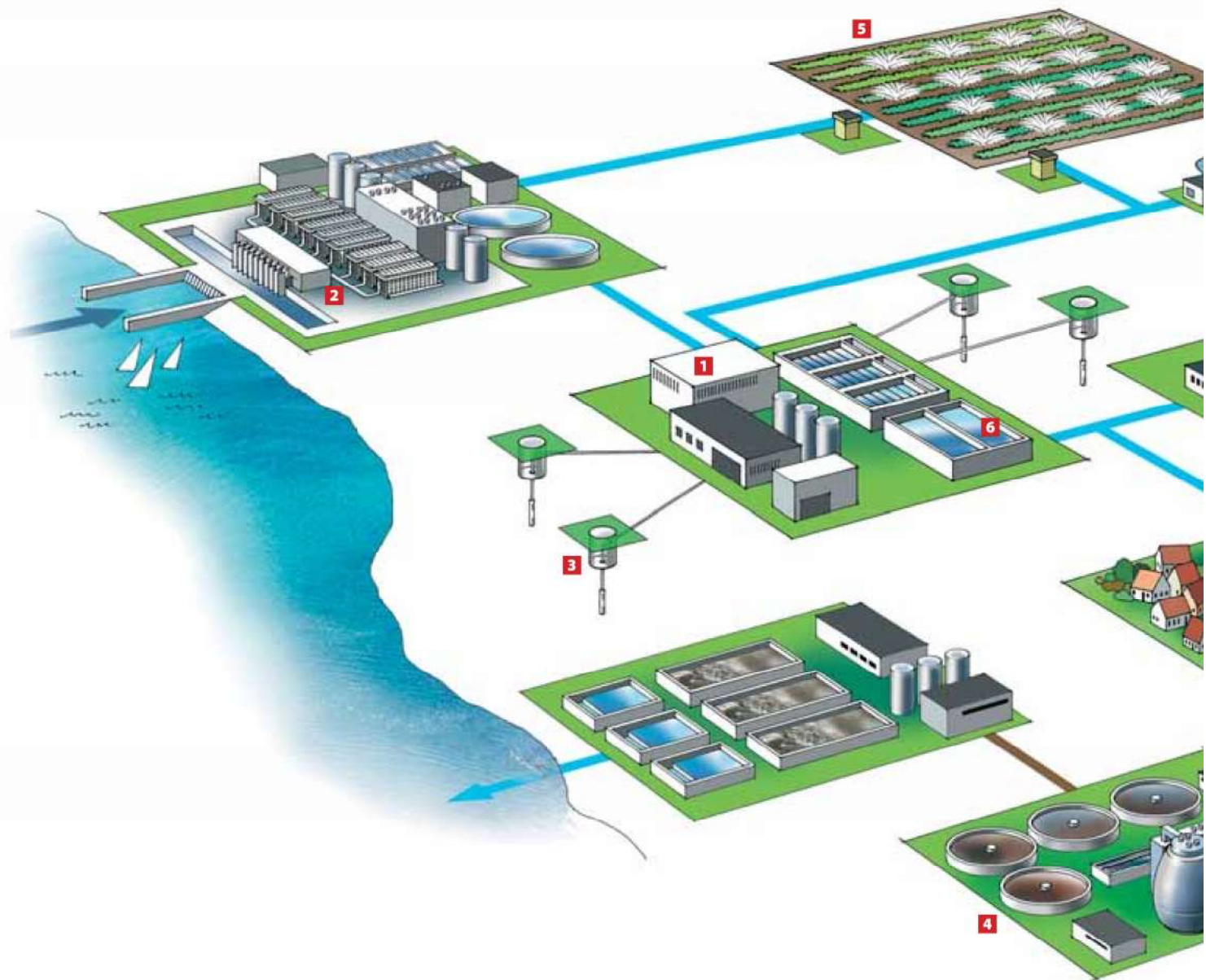

## 1 Water treatment plants

Meeting the varying flow demands on a daily or hourly basis requires reliable control. The VLT® AQUA Drive software provides unique pump control features that will help control even the most demanding applications.

## 2 Desalination plants

Desalination plants are used to provide clean drinking water from sea water or brackish water. In desalination plants saline environments often requires good

protection against corrosion. The optional high grade PCB coating and a mechanical design, which separates the electronics from the cooling air, makes the VLT® AQUA Drive the perfect solution for this application.

## 3 Groundwater pumps

Submersible deep well pumps need fast start and stop capability, precise control and protection against running dry. The built-in dry run detection and the initial and final ramp ramps make the

VLT® AQUA Drive handle such applications to perfection.

## 4 Wastewater plants

Fluctuations in flow can disrupt efficient process control, increase costs and equipment wear due to a higher number of starts and stops, and adversely affect effluent quality. Using the VLT® AQUA Drive on pumps, blowers and other equipment will lead to better process control and reduce energy consumption. The VLT® AQUA Drive can also provide

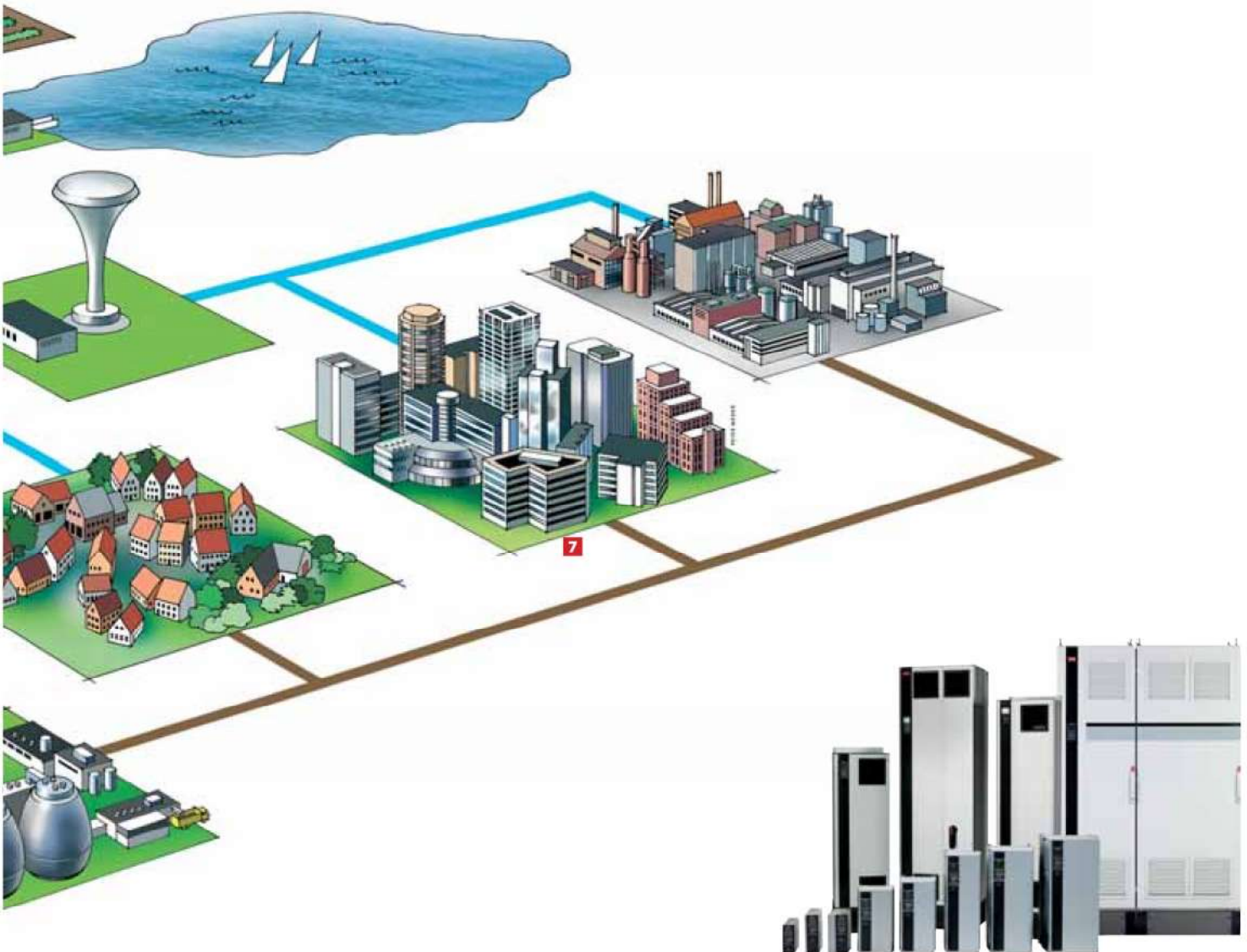

tighter control of chemical feed pumps, mixers and other equipment.

#### **5 Irrigation systems**

The irrigation market is focusing more and more on efficiency and energy savings for water management. Meeting these demands requires precise pressure and flow control. The built-in pump control features makes VLT® AQUA Drive a perfect match for irrigation in rural areas. It even offers a special pipe fill function that prevents water

hammering and reduces leakage when empty pipes are filled.

#### **6 Distribution**

As areas become more populated, the increasing demand for reliable and precise pressure control becomes a challenge to many communities. The VLT® AQUA Drive has innovative pumping functions to assist in maintaining precise pressure and flow while reducing system leakage and energy consumption. In many cases, it can also provide a

cost-effective alternative to water towers. The Cascade Controller has advanced distribution functions built-in.

#### **7 Water fountains and pools**

Water fountains are used to enhance the aesthetics of buildings and parks nearly everywhere. In these applications, the VLT® AQUA Drive can provide energy efficiency, accurate control and even meticulously timed sequencing for a dramatic effect.

# The modular VLT® AQUA Drive

## Extremely compact panel mount cabinets



C3 – frame IP 20 compact panel mounting drive.



Mains and motor cable terminals are located in the bottom of the cabinet for fast and easy installation.

The IP 20 enclosure has two individually controlled fans for maximum reliability.

Only a minimum of external cooling air passes the electronic components, which increases the lifetime.

The aluminium front hinged door ensures easy access to additional I/O options and control wiring.

IP 21/Type 1 protection can be delivered as a kit solution or as a specific IP 21 drive with easy access plastic cover with snap locks.

## Extremely robust cabinets for harsh environments



The Danfoss IP 55/NEMA 12 or IP 66 are designed for use in harsh environments with gas, pollution and dust. The electronics are completely separated from the cooling air in order to increase the lifetime.

All terminals and EMC connections are located inside the drive under the robust metal cover for maximum protection.

If ordered as IP 66 the heat sink is protected against corrosion (IP 66 rating is available up to 90 kW).

### 1 Fieldbus option

- Modbus RTU (std.)
- Modbus TCP IP
- PROFIBUS
- DeviceNet
- EtherNet/IP
- PROFINET

### 2 Local Control Panel (LCP)

Choose numerical, graphical or no display

### 3 I/O option

- General Purpose I/O (3DI + 2AI + 2DO + 1AO)
- Cascade controller (2 – 8 pumps)
- Sensor input (3 x PT100/1000 + 1AI)
- Relay output (3 x relays)

### 4 24 V supply option

### 5 RFI filter

Built-in RFI Filter for long motor cables according to the IEC 61800-3 and EN 55011 standards.

### 6 AC mains disconnect

(Factory mounted option)

### 7 Input mains option

Various input plate configurations are available including fuses, mains switch (disconnect), or RFI filter. Input plates are field adaptable if options need to be added after installation.

### 8 Coated PCB's

#### Durable in aggressive environments

In water and wastewater applications it is often recommended to protect the drive with coated PCB's. As standard the VLT® AQUA Drive complies with level 3C2 according to IEC 60721-3-3. Protection level 3C3 is optionally delivered from factory.

The option protects significantly better against chlorine, hydrogen sulphide, ammonia and other gasses.

**9 Unique cooling concept**

- No ambient air flow over electronics up to 90 kW
- Above 90 kW designed with back channel cooling (85% heat dissipated via back channel)

**10 Advanced cascade controller option**

Controls up to 9 pumps

**VLT® quality up to 1.4 MW**

The VLT® AQUA Drive is available from 0.25 kW to 1.4 MW.

Drive experience since 1968 lies behind the clever design of VLT® drives. All enclosures are mechanically designed with focus on:

- Robustness
- Easy access and installation
- Intelligent cooling
- High ambient temperatures
- Long service life

All VLT® AQUA Drives share technology, user interface and basic features with the rest of the new VLT® generation to assure well documented and proven quality.

The modular design of the VLT® AQUA Drive allows even highly customised drives to be mass produced and factory tested.

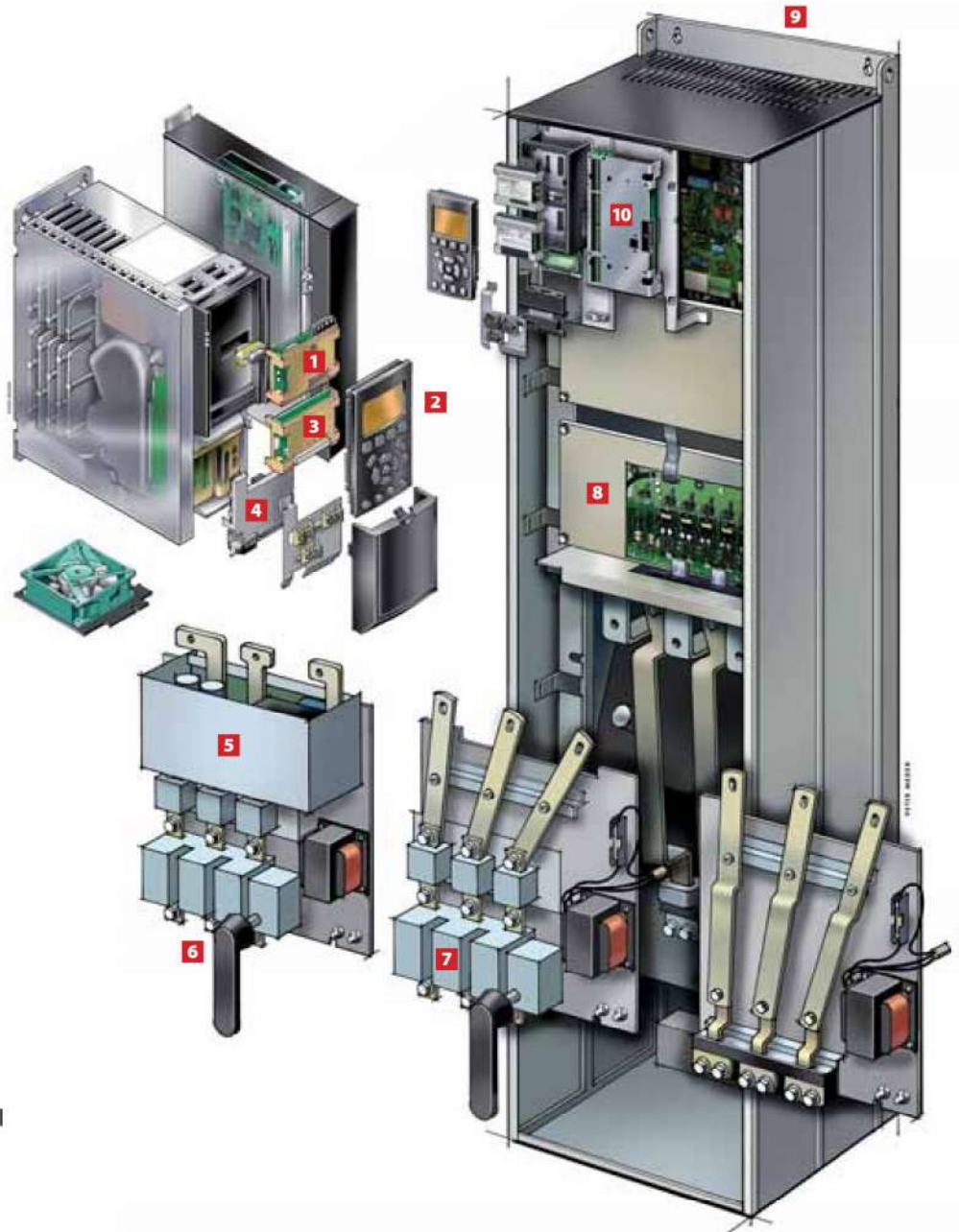

Remote access via fieldbus and USB cable. VLT® Set up Software MCT 10 gives intuitive access to all parameters and has scope features with graphs showing feedback, current, frequency etc. for easy fault finding and documentation.

DC coils reduce harmonic noise and protect the drive. Also EMC filters are integrated (meets EN 55011 A2, A1 or B).



# Dedicated water features

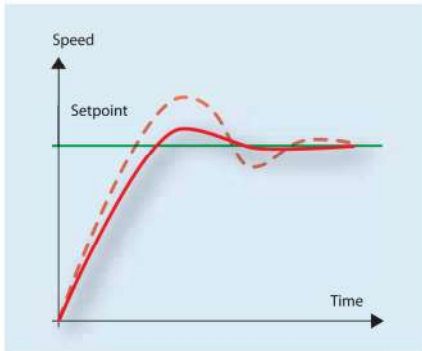

## Auto tuning of the PI controllers

With auto tuning of the PI controllers, the drive monitors how the system reacts on corrections made by the drive – and learns from it, so that precise and stable operation is achieved quickly.

Gain factors for PI are continuously changed to compensate for changing characteristics of the loads. This applies to each PI controller in the 4-menu sets individually. Exact P and I settings at start-up will not be necessary – which lowers the commissioning costs.

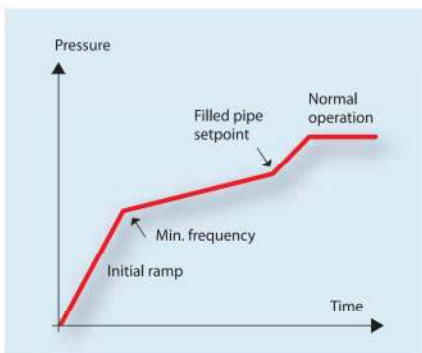

## Pipe Fill Mode

Enables controlled (closed loop) filling of pipes.

Prevents water hammering, bursting water pipes or blowing off sprinkler heads.

The new pipe fill mode is usable in both vertical and horizontal pipe systems.

Useful in all applications where controlled pipe filling is demanded, such as irrigation systems, water supply systems, etc.

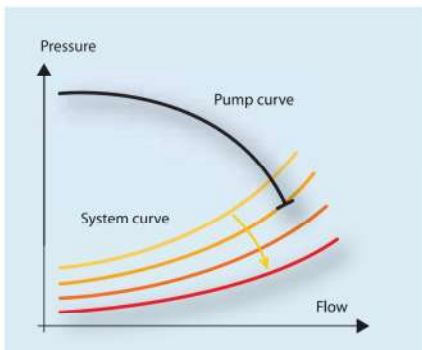

## End of Pump Curve detects breaks and leakage

The feature detects breaks and leakage. End of curve triggers an alarm, shuts off the pump, or performs another programmed action

whenever a pump is found running at full speed without creating the desired pressure – a situation that can arise when a pipe breaks or leakage occurs.

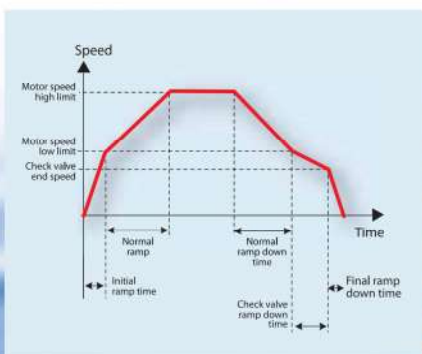

## Check Valve Ramp

The Check Valve Ramp prevents water hammering as the pump stops and the check valve closes.

The Check Valve Ramp slowly ramps down the pump speed around the value where the check valve ball is about to shut.



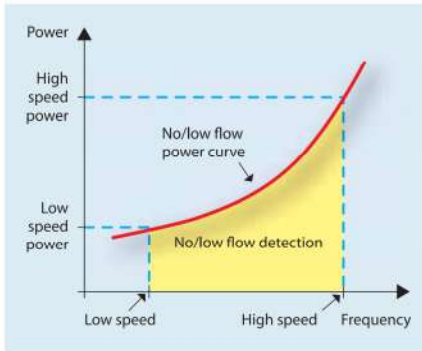

### Dry Run Detection lowers maintenance costs

The VLT® AQUA Drive constantly evaluates the condition of the pump, based on internal frequency/power measurements.

In case of a too low power consumption – indicating a no or low flow situation – the VLT® AQUA Drive will stop.

### Sleep Mode

Sleep Mode keeps pump wear and power consumption to an absolute minimum. In low flow situations, the pump will boost the system pressure and then stop.

Monitoring the pressure, the VLT® AQUA Drive will restart when the pressure falls below the required level.

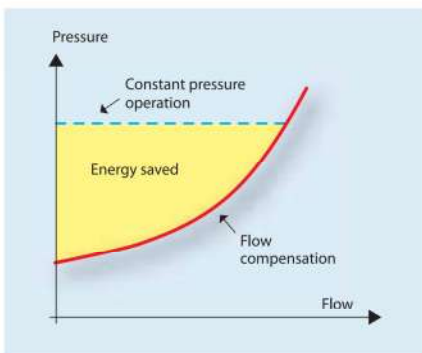

### Flow compensation

The flow compensation feature in VLT® AQUA Drive exploits the fact that flow resistance decreases with reduced flow. The pressure set point is accordingly reduced – which saves energy.

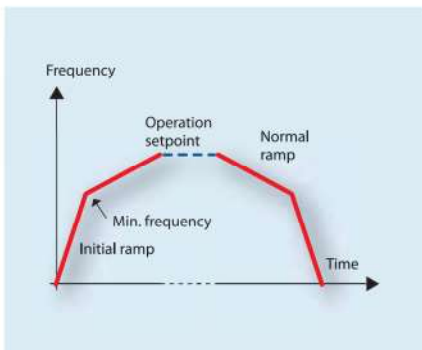

### Initial/Final Ramp

The initial ramp provides fast acceleration of pumps to minimum speed, from where the normal ramp takes over. This prevents damage to the thrust bearings on the pump.

The final ramp decelerates pumps from min. speed to stop.

### Payback time indication

One of the major reasons for applying a VLT® drive is the very short payback time due to energy savings. The VLT® AQUA drive comes with a unique feature which continuously shows the remaining payback time for the investment.

### Motor Alternation

This built-in logic controls alternation between two pumps in duty/stand-by applications. Motion of the stand-by pump prevents sticking of the pump. An internal timer assures equal usage of the pumps.

With an option card it is possible to control alternations between 8 pumps.

# Harmonics dissipation solutions for water and wastewater plants

Danfoss understands that water and wastewater treatment plants are frequently significant users of high power drives for pumps, compressors, aerators and so on, which by their very nature can generate substantial harmonic disturbance to the mains supply. This can be exacerbated when the plant is in an isolated location and supplied by a lengthy, high impedance power line. Add to this the fact that such plants also employ a great deal of sensitive electronic equipment such as sensors, telemetry, computer control systems and the like and it becomes clear that water and wastewater plants need drives with the lowest possible harmonic signature.

Danfoss has wide experience of water and wastewater plants across the globe and this is why all Danfoss VLT Drives come with built-in DC-coils to reduce the harmonics interference. In

many cases this is sufficient to avoid voltage pollution but in some cases additional harmonic suppression might be needed due to grid conditions or when multiple drives are installed.

## **Harmonic dissipation solutions**

Where the installation demands it, Danfoss can also offer the most comprehensive range of harmonics dissipation measures.

Passive filtering, especially in the lower power ranges, is a cost-effective method of reducing harmonic corruption of the mains. Danfoss AHF 005 and AHF 010 guarantee total current distortion lower than 5% and 10% respectively. The AHF filter range is both technically and physically, matched to the corresponding VLT® drive to ensure an efficient and compact solution.

Active filtering offers a greater degree of harmonic reduction, down to as low as a few percent. The VLT® Active Filters utilise proven drive technology to switch currents in phase opposition to the harmonic currents, effectively cancelling them out, working in the same way as noise cancelling headphones but on a much higher current level.

Danfoss also offers high power drives with in-built active filtering but a more economic solution on multi-drive sites might be to fit a larger active filter at the point of common coupling and thus provide a comprehensive harmonics dissipation solution for the plant as a whole.

## **Help is available**

Danfoss will, upon request, carry out a full harmonic survey and recommend the most appropriate and most



cost-effective solution for your site, taking into consideration the installed load, the regulatory norms to be met, the diversity factor of your operations and the needs of your installation for a high quality supply. Danfoss also offers free MCT 31 Harmonic Calculation software to help you calculate the harmonics and power quality of your site.

**Calculate the harmonic disturbance**  
Free to download, the VLT® Harmonic Calculation Tool MCT 31, is a simple to use, fast and accurate software tool for calculating the harmonic disruption

from your existing or intended drives installation. An accurate assessment is vital as in this case, more is not better, simply more costly, so the MCT 31 can help save money when selecting harmonic mitigation solutions.

The MCT 31 tool can easily be used to evaluate the grid quality and includes specific counter-measures to ease system stress. The power quality impact of electronic devices can be estimated in the frequency range up to 2.5 kHz, depending on the system configuration and standard limits. The analysis

includes indication of compliance with various standards and recommendations.

The Windows-like interface of the MCT 31 tool makes possible intuitive operation of the software. It is built with focus on user-friendliness and the complexity is limited to system parameters that are normally accessible. The Danfoss VLT® frequency converter data is already pre-loaded, allowing fast data entry.

## AQUA users participated in developing the user interface

### 1 Graphical display

- International letters and signs
- Graphical display with bar-charts
- Easy overview
- Possible to select 27 languages
- iF awarded design

### 2 Menu structure

- Based on the well known matrix-system in today's VLT® drives
- Easy shortcuts for the experienced user
- Edit and operate in different set-ups simultaneously

### 3 Other benefits

- Removable during operation
- Up- and download functionality
- IP 65 rating when mounted in a panel door
- Up to 5 different variables visible at a time



### 4 Illumination

- Relevant buttons are illuminated when active

### 5 Quick Menus

- A Danfoss defined Quick Menu
- A personal defined Quick Menu
- A Changes Made menu lists the parameters unique to your application
- A Function Setup menu provides quick and easy set-up for specific applications
- A Logging menu provides access to operation history

### 6 Intuitive functions

- Info ("on board manual")
- Cancel ("undo")
- Alarm log (quick access)

**iF** The VLT® AQUA Drive has an award-winning Local Control Panel and a well structured menu system that ensures fast commissioning and trouble-free operation of the many powerful functions.  
design award winner 2004

# Power, currents and enclosures ratings

FC 202	kW	T2 200 – 240 V								T4 380 – 480 V						T6 525 – 600 V				T7 525 – 690 V											
		1 ph			3 ph					1 ph			3 ph			A				A.											
		Amp.	IP 20	IP 55	IP 66	IP 20	IP 21	IP 55	IP 66	≤440 V	>440 V	All IP cl*	≤440 V	>440 V	IP 00	IP 20	IP 21	IP 54	IP 55	IP 66	≤550 V	>550 V	IP 20	IP 21	IP 55	IP 66	550 V	690 V	IP 00	IP 21	IP 54/55
PK25	0.25	1.8																													
PK37	0.37	2.4																													
PK55	0.55	3.5																													
PK75	0.75	4.6																													
P1K1	1.1	6.6	A3	A5	A5	A2	A2	A4/A5	A4/A5																						
P1K5	1.5	7.5																													
P2K2	2.2	10.6																													
P3K0	3	12.5	B1	B1																											
P3K7	3.7	16.7																													
P4K0	4.0																														
P5K5	5.5	24.2	B1	B1																											
P7K5	7.5	30.8	B2	B2	B3	B1	B1	B1																							
P11K	11	46.2																													
P15K	15	59.4	C1	C1	B4	B2	B2	B2																							
P18K	18	74.8																													
P22K	22	88	C2	C2	C3	C1	C1	C1																							
P30K	30	115																													
P37K	37	143																													
P45K	45	170																													
P55K	55																														
P75K	75																														
P90K	90																														
P110	110																														
P132	132																														
P160	160																														
P200	200																														
P250	250																														
P315	315																														
P355	355																														
P400	400																														
P450	450																														
P500	500																														
P560	560																														
P630	630																														
P710	710																														
P800	800																														
P900	900																														
P1M0	1000																														
P1M2	1200																														
P1M4	1400																														

F3 is a F1 frame with options cabinet; F4 is a F2 frame with options cabinet

IP 00/Chassis	IP 20/Chassis	IP 21/NEMA Type 1	With upgrade kit**	IP 54/NEMA Type 12	IP 55/NEMA Type 12	IP 66/NEMA Type 4X
---------------	---------------	-------------------	--------------------	--------------------	--------------------	--------------------

\* Available in all IP classes. \*\* MCF 101 – IP 21 upgrade kit

## Dimensions [mm]

	A2	A3	A4	A5	B1	B2	B3	B4	C1	C2	C3	C4	D1	D2	D3	D4
H	268		420	420	480	650	399	520	680	770	550	660	1209	1589	1046	1327
W	90	130	200		242		165	230	308	370	308	370	420		408	
D	205		177 (213)	200	260		249	242	310	335		333	380		375	
H+	375						475	670			755	950				
W+	90	130					165	255			329	391				

H and W dimensions are with back-plate. H+ and W+ are with IP upgrade kit. D dimensions are without option.

# Choose configurations freely

[1] [2] [3] [4] [5] [6] [7] [8] [9] [10] [11] [12] [13] [14] [15] [16] [17] [18]  
**FC-202** – [ ] – [ ] – [ ] – [ ] – [ ] – [ ] – [ ] – [ ] – [ ] – X – SXX X – X – [ ] – [ ] – CX – [ ] – XX – [ ]

[1] Application	
202	VLT® AQUA Drive FC 202

[2] Power Size	
PK25	
PK37	
PK55	
PK75	
P1K1	
P1K5	
P2K2	
P3K0	
P3K7	
P4K0	
P5K5	
P7K5	
P11K	
P15K	
P18K	
P22K	
P30K	
P37K	
P45K	
P55K	See ratings data on page 12 for power ratings
P75K	
P90K	
P110	
P132	
P160	
P200	
P250	
P315	
P355	
P400	
P450	
P500	
P560	
P630	
P710	
P800	
P900	
P1M0	
P1M2	
P1M4	

[3] AC Line Voltage	
T2	1 x 200/240 V AC (1.1 – 45 kW)
T2	3 x 200/240 V AC (1.1 – 45 kW)
T4	1 x 380/480 V AC
T4	3 x 380/480 V AC
T6	3 x 525/600 V AC (1.1 – 90 kW)
T7	3 x 525/690 V AC (45 kW – 1.4 MW)

[4] Enclosure	
For cabinet mounting:	
E00	IP 00 (enclosure D3, D4)
E20	IP 20 (enclosure A2, A3, B3, B4, C3, C4)
Standalone:	
E21	IP 21 (enclosure B1, B2, C1, C2, D1, D2, E, F)
E54	IP 54 (enclosure D1, D2, E, F)
E55	IP 55 (enclosure A4, A5, B1, B2, C1, C2)
E66	IP 66 (enclosure A4, A5, B1, B2, C1, C2)
Z55	IP 55 (enclosure A4)
Special designs:	
C00	IP 00 (enclosure E00 – air duct in stainless steel)
P20	IP 20 (enclosure B4, C3, C4 – Back Plate)
E2M	IP 21 (enclosure D1, D2 – protective cover)
P21	IP 21 (enclosure as E21 – Back Plate)
E5M	IP 54 (enclosure D1, D2 – protective cover)
P55	IP 55 (enclosure as E55 – Back Plate)
ESH	Special LHD enclosure IP 54 electronic IP 21 magnetics
Y55	IP 55 (enclosure as Z55 – Back Plate)

[5] RFI Filter (EN/IEC 61800-3)	
H1	RFI-Filter Class C1/C2 (enclosure A, B, C)
H2	RFI-Filter, Class C3 (enclosure A, B, C, D, E, F)
H3	RFI-Filter Class C1/C2 (enclosure A, B, C)
H4	RFI-Filter, Class C2 (enclosure D, E, F)
H6	RFI-Filter for Marine
HX	No RFI-Filter (enclosure A, B, C, 525 – 600 V)
L2	Low Harmonic Drive with RFI Class C3
L4	Low Harmonic Drive with RFI Class C2
B2	12-pulse with A2 RFI Class C3
B4	12-pulse with A1 RFI Class C2

[6] Braking & Safety	
X	No brake IGBT
B	Brake IGBT mounted
T	Safe stop without brake
U	With brake and Safe Stop

[7] Display (Local Control Panel)	
X	Blank faceplate, no LCP installed
G	LCP 101 – Graphic LCP installed
N	LCP 102 – Numeric LCP installed

[8] Conformal Coating (IEC 721-3-3)	
X	No conformal coating
C	Conformal coating on all PCBs

[9] Mains Input	
X	No option
1	Mains disconnect
3	Mains disconnect and fuses
5	Mains disconnect, fuses and load sharing
7	Fuses
A	Fuses & load sharing terminals
D	Load sharing terminals

[10] Cable	
X	Standard Cable Entries
O	Metric Cable Entries

[13] A Option (Fieldbus)	
AX	No fieldbus option
A0	MCA 101 – PROFIBUS DPV1
A4	MCA 104 – DeviceNet
AL	MCA 120 – PROFINET RT
AN	MCA 121 – Ethernet I/P
AQ	MCA 122 – Modbus TCP

[14] B Option (Application)	
BX	No application option
BK	MCB 101 – General Purpose I/O
BP	MCB 105 – Relay Expansion
B0	MCB 109 – Analog I/O
B4	MCB 114 – Sensor Input Option
BY	MCO 105 – Extended Cascade Controller

[16] C1 Option (Extended Relay)	
X	No application option
5	MCO 102 – Advanced Cascade Controller

[18] D Option (Control Power Backup Input)	
DX	No DC input installed
D0	MCB 107 24 VDC backup input

**Please beware that not all combinations are possible. Find help configuring your drive with the online configurator found under: [driveconfig.danfoss.com](http://driveconfig.danfoss.com)**

## An overview showing the many ways to configure a VLT® AQUA Drive

Select the options required for your application to determine the type code for your drive. The factory then uses this type code to build the drive to your exact specifications.

You can configure online at [www.danfoss.com/drives](http://www.danfoss.com/drives) – choose “Online Configurator” – or contact your local Danfoss VLT Drives office.

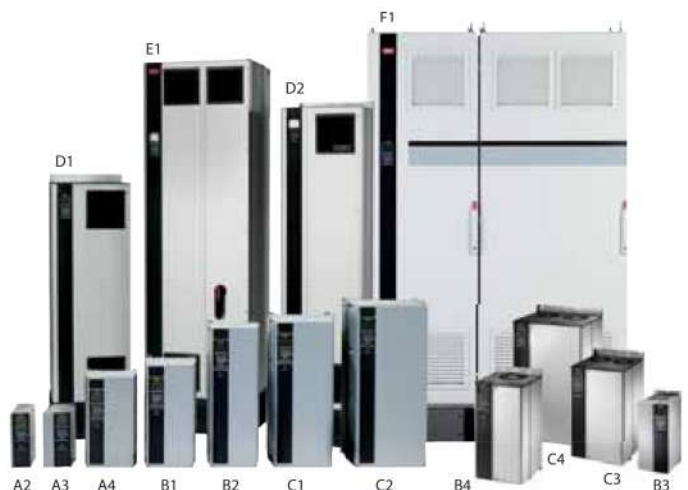

# Specifications

Mains supply (L1, L2, L3)	
Supply voltage	1 or 3 x 200 – 240 V ±10% 1 or 3 x 380 – 480 V ±10% 3 x 525 – 600 V ±10% 3 x 525 – 690 V ±10%
Supply frequency	50/60 Hz
True power factor (λ)	≥ 0.9
Switching on input supply L1, L2, L3	1-2 times/min.

Output data (U, V, W)	
Output voltage	0 – 100% of supply voltage
Switching on output	Unlimited
Ramp times	1 – 3600 sec
Closed loop	0 – 132 Hz

VLT® AQUA Drive can provide 110% current for 1 minute.  
Higher overload rating is achieved by oversizing the drive.

Digital inputs	
Programmable digital inputs	6*
Logic	PNP or NPN
Voltage level	0–24 V
Thermistor inputs	1

\*2 can be used as digital outputs

Analog input	
Analog inputs	2
Modes	Voltage or current
Voltage level	0 – 10 V (scaleable)
Current level	0/4 – 20 mA (scaleable)

Pulse inputs	
Programmable pulse inputs	2
Voltage level	0-24 VDC (PNP positive logic)
Pulse input accuracy	(0.1 – 110 kHz)
Utilize some of the digital inputs	

Analog output	
Programmable analog outputs	1
Current range at analog output	0/4 – 20 mA
Max. load (24 V)	130 mA

Relay outputs	
Programmable relay outputs (240 VAC, 2 A and 400 VAC, 2 A)	2

Fieldbus communication	
Standard built in: FC Protocol Modbus RTU	Optional: PROFIBUS DeviceNet EtherNet/IP Modbus TCP IP PROFINET

Temperature	
Ambient temperature	Up to 55° C

## Application options

A wide range of integrated water application options can be fitted into the drive:

- **Real time clock with battery back-up**
- **General purpose I/O option:**  
3 digital inputs, 2 digital outputs, 1 analog current output, 2 analog voltage inputs
- **Relay option/cascade controller option:**  
3 relay outputs
- **External 24 VDC supply option:**  
24 VDC external supply can be connected to supply control and option cards
- **Brake chopper option:**  
Connected to an external brake resistor, the brake chopper limits the load on the intermediate circuit in case the motor acts as generator.
- **Extended cascade control of up to a total of 6 pumps**
- **Advanced cascade control of up to a total of 9 pumps**
- **Analogue sensor input option with up to 3 temperature sensor inputs**

## Power options

Danfoss VLT Drives offers a wide range of external power options for use together with our drive in critical networks or applications:

- **Advanced Harmonic Filters:** for applications where reducing harmonic distortion is critical
- **dU/dt filters:** For providing motor isolation protection
- **Sine filters (LC filters):** For noiseless motor

## Complementary products

- A broad range of soft starters
- Decentral drive solutions

## PC software

- **MCT 10**  
Ideal for commissioning and servicing the drive including guided programming of cascade controller, real time clock, smart logic controller and preventive maintenance. The software is available for free on [www.danfoss.com](http://www.danfoss.com)
- **VLT® Energy Box**  
Comprehensive energy analysis tool, shows the drive payback time
- **MCT 31**  
Harmonics calculations tool

**Sales and Service Contacts worldwide**  
Find your local expert team on [www.danfoss.com/drives](http://www.danfoss.com/drives)

- 24/7 availability
- Local service organisation is present in more than 100 countries – ready to support whenever and wherever you need, around the clock, 7 days a week.



Global Marine

# Connection examples

The numbers represent the terminals on the drive

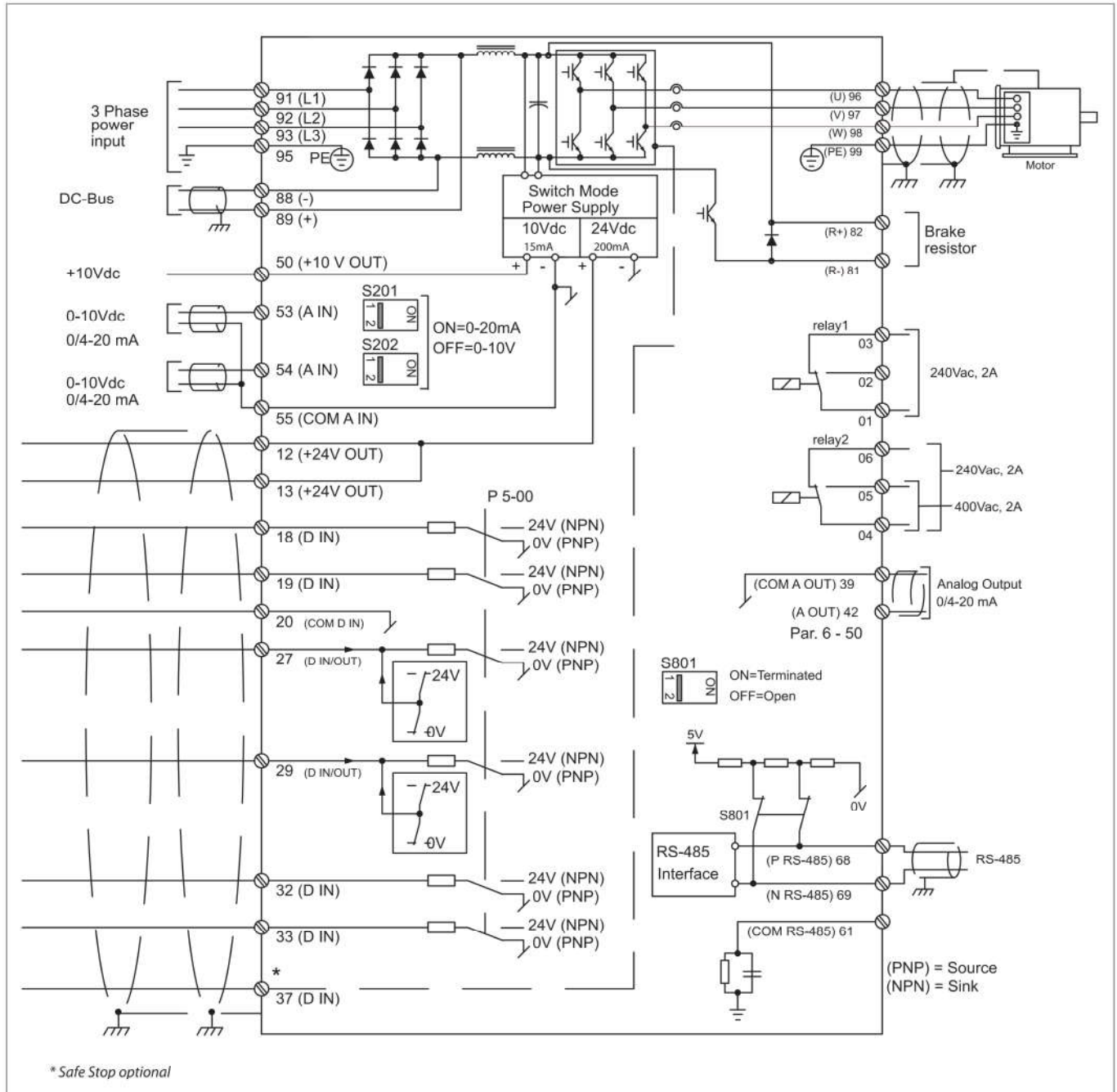

This diagram shows a typical installation of the VLT® AQUA Drive. Power is connected to the terminals 91 (L1), 92 (L2) and 93 (L3) and the motor is connected to 96 (U), 97 (V) and 98 (W).

Terminals 88 and 89 are used for load sharing between drives. Analogue inputs can be connected to

the 53 (V or mA), 54 (V or mA) terminals.

These inputs can be set up to either reference, feedback or thermistor. There are 6 digital inputs to be connected to terminals 18, 19, 27, 29, 32, and 33. Two digital input/output terminals (27 and 29) can be set up

as digital outputs to show an actual status or warning. The terminal 42 analogue output can show process values such as  $0 - I_{max}^*$ .

On the 68 (P+) and 69 (N-) terminals' RS 485 interface, the drive can be controlled and monitored via serial communication.

# Proven AQUA Experience – world wide



**Freshwater supply for the city Novi Sad, Serbia**  
In the city of Novi Sad in Serbia, Danfoss VLT Drives has installed 5 x 315 kW VLT® AQUA Drives in JKP Vodovod. The company JKP Vodovod is using water from the Danube River and after purification it is provided to people of Novi Sad and local area which counts around 350,000 inhabitants. Before investments they used an old regulation with valves and there was no central monitoring of the water system. Poor regulation and high maintenance costs have forced local management for investments. Now they have seen huge savings in electrical energy, even within a short period of usage.



**VLT® drives make 70 billion litres of Sydney's wastewater drinkable**  
Authorities in Australia hope to recycle 70 billion litres of Sydney's wastewater every year by 2015 – and Danfoss is playing a key role in helping them hit this ambitious target. Danfoss VLT Drives will deliver 11 x 200 – 400 kW High Power drives and AHF filters for the Western Sydney Replacement Flows Project. The Aus \$250 million project is Sydney's largest water recycling scheme and is a key part of the state's Metropolitan Water Plan.



**Changi Water Reclamation Plant, Singapore**  
The Changi Water Reclamation plant is the cornerstone of the first phase of the Singapore Deep Tunnel Sewerage System. The plant is to replace six existing water reclamation plants in the long term. Danfoss VLT® drives and AHF filters were supplied for chemical and carbon scrubbers for the odour control, sedimentation tanks, bio-reactors, sedimentation tanks and solids building.



**Perth Seawater Desalination Plant, Australia**  
VLT® drives and soft starters were chosen to run pumps when The Water Corporation of Western Australia – one of Australia's largest and most successful water service providers – invested \$387 million Australian dollars in Perth Seawater Desalination Plant – the largest of its type in the Southern Hemisphere. The company provides water and wastewater services to the burgeoning city of Perth and hundreds of towns and communities spread over 2.5 million square kilometres.



**Wastewater Pumping in Cartagena, Colombia**  
Huge energy savings and a significant carbon reduction were achieved in the preliminary water treatment stage, where solids are separated from the sewage inflow. By applying Danfoss VLT® AQUA Drives to control the levels in the holding tanks, variable speed operation of the 4 x 370 kW pumps realised a return on investment within 6 months, and ongoing energy and carbon savings for the future. The additional operation result is a more constant flow through the subsequent processes, improving overall process efficiency



**Xi'An No.3 Waste Water treatment, China**  
Danfoss provided VLT® AQUA drives and MCD soft starters for Xi'An No.3 Wastewater treatment plant. It is one of three bundles of a retrofit project to improve the environment in Xi'An City of Shanxi province, China. The treatment capacity is 100,000 tons of sewage and 50,000 tons of recycled water per day.



**Athens Wastewater Treatment Plant, Greece**  
VLT® drives up to 315 kW handle wastewater from a population of 5 million in Athens. VLT® operation saves approx. 25% energy. The Psytalia Wastewater Treatment Plant treats daily 750,000 m<sup>3</sup> of sewage and has a nominal daily capacity of 1,000,000 m<sup>3</sup>.



**Vienna's Main Sewage Treatment Plant, Austria**  
At Vienna's lowest point, where the Danube Canal meets the Danube, lies Vienna's Main Sewage Treatment Plant. Here around 90% of Vienna's wastewaters is purified. VLT® drives were chosen to operate the pumps that handle more than 500,000 cubic metres per day, which corresponds to a flow of a medium-size river.



**Izmir Geothermal District Heating System, Turkey**  
VLT® drives operate the deep well and supply pumps in Izmir geothermal district heating. Applying VLT® drives leads to a very low electricity cost.



# 1 x 200 – 240 VAC and 1 x 380 – 480 VAC

## 1 x 200 – 240 VAC

Enclosure	IP 20 /Chassis		A3	B1					B2	C1	C2	
	IP 55 + IP 66 /NEMA 12		A5	P1K1	P1K5	P2K2	P3K0	P3K7	P5K5	P7K5	P15K0	P22K0
<b>Typical Shaft Output</b>		[kW]	1.1	1.5	2.2	3	3.7	5.5	7.5	15	22	
<b>Typical Shaft Output at 240 V</b>		[HP]	1.5	2.0	2.9	4.0	4.9	7.5	10	20	30	
<b>Output Current</b> (1 x 200 – 240 V)	Continuous	[A]	6.6	7.5	10.6	12.5	16.7	24	30.8	59.4	88	
	Intermittent	[A]	7.3	8.3	11.7	13.8	18.4	26.6	33.4	65.3	96.8	
<b>Output Power</b> (208 V AC)	Continuous	[kVA]						5.00	6.40	12.27	18.30	
<b>Max. cable size</b> (Mains, motor, brake)		[mm <sup>2</sup> ] ([AWG])	0.2-4/4-10					10/7	35/2	50/1/0	95/4/0	
<b>Max. Input Current</b> (1 x 200 – 240 V)	Continuous	[A]	12.5	15	20.5	24	32	46	59	111	172	
	Intermittent	[A]	13.8	16.5	22.6	26.4	35.2	50.6	64	122	189.2	
<b>Max. pre-fuses</b>		[A]	20	30	40	60	80	100	150	200		
<b>Environment</b>												
<b>Estimated power loss at rated max. load</b>		[W]	44	30	44	60	74	110	150	300	440	
<b>Weight</b>												
IP 20		[kg]	4.9									
IP 21		[kg]		23					27	45	65	
IP 55, IP 66		[kg]		23					27	45	65	
<b>Efficiency</b>			0.968						0.98			

## 1 x 380 – 480 VAC

Enclosure	IP 20 (IP 21*)/Chassis		B1	B2	C1	C2	
	IP 21/NEMA 1, IP 55 + IP 66/NEMA 12		P7K5	P11K	P18K	P37K	
<b>Typical Shaft Output</b>		[kW]	7.5	11	18.5	37	
<b>Typical Shaft Output at 460 V</b>		[HP]	10	15	25	50	
<b>Output Current</b> (1 x 380 – 440 V)	Continuous	[A]	33	48	78	151	
	Intermittent	[A]	36	53	85.8	166	
<b>Output Current</b> (1 x 441 – 480 V)	Continuous	[A]	30	41	72	135	
	Intermittent	[A]	33	46	79.2	148	
<b>Output Power</b> (208 V AC)	Continuous	[kVA]	11.1	16.6	26.9	51.5	
<b>Max. cable size</b> Mains, motor, brake		[mm <sup>2</sup> ] ([AWG])	10/7	35/2	50/1/0	120/4/0	
<b>Max. Input Current</b> (1 x 380 – 440 V)	Continuous	[A]	33	48	78	151	
	Intermittent	[A]	36	53	85.8	166	
<b>Max. Input Current</b> (1 x 441 – 480 V)	Continuous	[A]	30	41	72	135	
	Intermittent	[A]	33	46	79.2	148	
<b>Max. pre-fuses</b>		[A]	63	80	160	250	
<b>Environment</b>							
<b>Estimated power loss at rated max. load</b>		[W]	300	440	740	1480	
<b>Weight</b>							
IP 20, IP 21, IP 55, IP 66		[kg]	23	27	45	65	
<b>Efficiency</b>							0.96

# 3 x 200 – 240 VAC

Enclosure	IP 20 (IP 21*)/Chassis		A2							A3	
	IP 55 + IP 66 /NEMA 12		A4 + A5							A5	
			PK25	PK37	PK55	PK75	P1K1	P1K5	P2K2	P3K0	P3K7
<b>Typical Shaft Output</b>		[kW]	0.25	0.37	0.55	0.75	1.1	1.5	2.2	3	3.7
<b>Typical Shaft Output at 208 V</b>		[HP]	0.25	0.37	0.55	0.75	1.5	2.0	2.9	4.0	4.9
<b>Output Current</b> (3 x 200 – 240 V)	Continuous	[A]	1.8	2.4	3.5	4.6	6.6	7.5	10.6	12.5	16.7
	Intermittent	[A]	1.98	2.64	3.85	5.06	7.3	8.3	11.7	13.8	18.4
<b>Output Power</b> (208 V AC)	Continuous	[kVA]	0.65	0.86	1.26	1.66	2.38	2.70	3.82	4.50	6.00
<b>Max. cable size</b> (Mains, motor, brake)		[mm <sup>2</sup> ] ([AWG])	4 (10)								
<b>Max. Input Current</b> (3 x 200 – 240 V)	Continuous	[A]	1.6	2.2	3.2	4.1	5.9	6.8	9.5	11.3	15.0
	Intermittent	[A]	1.7	2.42	3.52	4.51	6.5	7.5	10.5	12.4	16.5
<b>Max. pre-fuses</b>		[A]	10				20			32	
<b>Environment</b>											
<b>Estimated power loss at rated max. load</b>		[W]	21	29	42	54	63	82	116	155	185
<b>Weight</b>											
IP 20		[kg]					4.9			6.6	
IP 21		[kg]					5.5			7.5	
IP 55, IP 66		[kg]					13.5				
<b>Efficiency</b>			94		95		0.96				

Enclosure	IP 20 (IP 21*)/Chassis		B3			B4		C3		C4	
	IP 21/NEMA 1, IP 55 + IP 66/NEMA 12		B1			B2	C1		C2		
			P5K5	P7K5	P11K	P15K	P18K	P22K	P30K	P37K	P45K
<b>Typical Shaft Output</b>		[kW]	5.5	7.5	11	15	18.5	22	30	37	45
<b>Typical Shaft Output at 208 V</b>		[HP]	7.5	10	15	20	25	30	40	50	60
<b>Output Current</b> (3 x 200 – 240 V)	Continuous	[A]	24.2	30.8	46.2	59.4	74.8	88.0	115	143	170
	Intermittent	[A]	26.6	33.9	50.8	65.3	82.3	96.8	127	157	187
<b>Output Power</b> (208 V AC)	Continuous	[kVA]	8.7	11.1	16.6	21.4	26.9	31.7	41.4	51.5	61.2
<b>Max. cable size</b> Mains, motor, brake		[mm <sup>2</sup> ] ([AWG])	10 (7)			35 (2)	50 (1/0) (B4 = 35 (2))		95 (4/0)	120 (250 MCM)	
<b>Max. cable size mains</b> With mains disconnect switch included		[mm <sup>2</sup> ] ([AWG])	16 (6)			35 (2)		70 (3/0)		185 (kcmil 350)	
<b>Max. Input Current</b> (3 x 200 – 240 V)	Continuous	[A]	22.0	28.0	42.0	54.0	68.0	80.0	104.0	130.0	154.0
	Intermittent	[A]	24.2	30.8	46.2	59.4	74.8	88.0	114.0	143.0	169.0
<b>Max. pre-fuses</b>		[A]	63	63	63	80	125	125	160	200	250
<b>Environment</b>											
<b>Estimated power loss at rated max. load</b>		[W]	269	310	447	602	737	845	1140	1353	1636
<b>Weight</b>											
IP 20		[kg]	12			23.5		35		50	
IP 21, IP 55, IP 66		[kg]	23			27		45		65	
<b>Efficiency</b>			0.96				0.97				

\* (A2, A3, B3, B4, C3 and C4 may be converted to IP21 using a conversion kit.  
(Please see also items Mechanical mounting in Operating Instructions and IP 21/ Type 1 Enclosure kit in the Design Guide.))

# 380 – 480 VAC

Enclosure	IP 20 (IP 21*)/Chassis		A2								A3		
	IP 55 + IP 66 /NEMA 12		A4 + A5								A5		
			PK37	PK55	PK75	P1K1	P1K5	P2K2	P3K0	P4K0	P5K5	P7K5	
<b>Typical Shaft Output</b>		[kW]	0.37	0.55	0.75	1.1	1.5	2.2	3	4	5.5	7.5	
<b>Typical Shaft Output at 460 V</b>		[HP]	0.5	0.75	1.0	1.5	2.0	2.9	4.0	5.0	7.5	10	
<b>Output Current</b> (3 x 380 – 440 V)	Continuous	[A]	1.3	1.8	2.4	3	4.1	5.6	7.2	10	13	16	
	Intermittent	[A]	1.43	1.98	2.64	3.3	4.5	6.2	7.9	11	14.3	17.6	
<b>Output Current</b> (3 x 441 – 480 V)	Continuous	[A]	1.2	1.6	2.1	2.7	3.4	4.8	6.3	8.2	11	14.5	
	Intermittent	[A]	1.32	1.76	2.31	3.0	3.7	5.3	6.9	9.0	12.1	15.4	
<b>Output Power</b> (400 V AC)	Continuous	[kVA]	0.9	1.3	1.7	2.1	2.8	3.9	5.0	6.9	9.0	11.0	
<b>Output Power</b> (460 V AC)	Continuous	[kVA]	0.9	1.3	1.7	2.4	2.7	3.8	5.0	6.5	8.8	11.6	
<b>Max. cable size</b> (Mains, motor, brake)		[mm <sup>2</sup> ] ([AWG])	4 (10)										
<b>Max. Input Current</b> (3 x 380 – 440 V)	Continuous	[A]	1.2	1.6	2.2	2.7	3.7	5.0	6.5	9.0	11.7	14.4	
	Intermittent	[A]	1.32	1.76	2.42	3.0	4.1	5.5	7.2	9.9	12.9	15.8	
<b>Max. Input Current</b> (3 x 441 – 480 V)	Continuous	[A]	1.0	1.4	1.9	2.7	3.1	4.3	5.7	7.4	9.9	13.0	
	Intermittent	[A]	1.1	1.54	2.09	3.0	3.4	4.7	6.3	8.1	10.9	14.3	
<b>Max. pre-fuses</b>		[A]	10					20			32		
<b>Environment</b>													
<b>Estimated power loss at rated max. load</b>		[W]	35	42	46	58	62	88	116	124	187	255	
<b>Weight</b>													
IP 20		[kg]	4.7		4.8			4.9			6.6		
IP 55, IP 66		[kg]	13.5										14.2
<b>Efficiency</b>			0.93	0.95	0.96			0.97					

Enclosure	IP 20 (IP 21*)/Chassis		B3			B4			C3			C4	
	IP 21/NEMA 1, IP 55 + IP 66/NEMA 12		B1			B2			C1			C2	
			P11K	P15K	P18K	P22K	P30K	P37K	P45K	P55K	P75K	P90K	
<b>Typical Shaft Output</b>		[kW]	11	15	18.5	22	30	37	45	55	75	90	
<b>Typical Shaft Output at 460 V</b>		[HP]	15	20	25	30	40	50	60	75	100	125	
<b>Output Current</b> (3 x 380 – 439 V)	Continuous	[A]	24	32	37.5	44	61	73	90	106	147	177	
	Intermittent	[A]	26.4	35.2	41.3	48.4	67.1	80.3	99	117	162	195	
<b>Output Current</b> (3 x 440 – 480 V)	Continuous	[A]	21	27	34	40	52	65	80	105	130	160	
	Intermittent	[A]	23.1	29.7	37.4	44	61.6	71.5	88	116	143	176	
<b>Output Power</b> (400 V AC)	Continuous	[kVA]	16.6	22.2	26	30.5	42.3	50.6	62.4	73.4	102	123	
<b>Output Power</b> (460 V AC)	Continuous	[kVA]	16.7	21.5	27.1	31.9	41.4	51.8	63.7	83.7	104	128	
<b>Max. cable size</b> Mains, motor, brake		[mm <sup>2</sup> ] ([AWG])	10 (7)			35 (2)			50 (1/0) (B4 = 35 (2))			95 (4/0)	120 (250 MCM) <sup>1)</sup>
<b>Max. cable size mains</b> With mains disconnect switch included		[mm <sup>2</sup> ] ([AWG])	16 (6)						35 (2)			70 (3/0)	185 (kcmil 350)
<b>Max. Input Current</b> (3 x 380 – 439 V)	Continuous	[A]	22	29	34	40	55	66	82	96	133	161	
	Intermittent	[A]	24.2	31.9	37.4	44	60.5	72.6	90.2	106	146	177	
<b>Max. Input Current</b> (3 x 440 – 480 V)	Continuous	[A]	19	25	31	36	47	59	73	95	118	145	
	Intermittent	[A]	20.9	27.5	34.1	39.6	51.7	64.9	80.3	105	130	160	
<b>Max. pre-fuses</b>		[A]	63	63	63	63	80	100	125	160	250	250	
<b>Environment</b>													
<b>Estimated power loss at rated max. load</b>		[W]	278	392	465	525	698	739	843	1083	1384	1474	
<b>Weight</b>													
IP 20		[kg]	12			23.5			35			50	
IP 21, IP 55, IP 66		[kg]	23			27			45			65	
<b>Efficiency</b>			0.98										0.99

\* (A2, A3, B3, B4, C3 and C4 may be converted to IP21 using a conversion kit. Please contact Danfoss.  
(Please see also items Mechanical mounting in Operating Instructions and IP 21/ Type 1 Enclosure kit in the Design Guide.))

1) With brake and load sharing 95 (4/0)

# 380 – 480 VAC

Enclosure	IP 21, IP 54		D1		D2		
	IP 00		D3		D4		
			P110	P132	P160	P200	P250
<b>Typical Shaft Output at 400 V</b>	[kW]		110	132	160	200	250
<b>Typical Shaft Output at 460 V</b>	[HP]		150	200	250	300	350
<b>Output Current</b>							
Continuous (3 x 380 – 400 V)	[A]		212	260	315	395	480
Intermittent (3 x 380 – 400 V)	[A]		233	286	347	435	528
Continuous (3 x 441 – 480 V)	[A]		190	240	302	361	443
Intermittent (3 x 441 – 480 V)	[A]		209	264	332	397	487
<b>Output Power</b>							
Continuous (400 VAC)	[kVA]		147	180	218	274	333
Continuous (460 VAC)	[kVA]		151	191	241	288	353
<b>Max. Input Current</b>							
Continuous (3 x 380 – 400 V)	[A]		204	251	304	381	463
Continuous (3 x 441 – 480 V)	[A]		183	231	291	348	427
<b>Max. cable size</b> Mains motor, brake and load share	[mm <sup>2</sup> ] ([AWG])		2 x 70 (2 x 2/0)		2 x 150 (2 x 300 mcm)		
<b>Max. external pre-fuses</b>	[A]		300	350	400	500	630
<b>Estimated power loss at rated max. load – 400 V</b>	[W]		2907	3358	3915	4812	5517
<b>Estimated power loss at rated max. load – 460 V</b>	[W]		2600	3079	3781	4535	5024
<b>Weight</b>	IP 21, IP 54	[kg]	96	104	125	136	151
	IP 00	[kg]	82	91	112	123	138
<b>Efficiency</b>			0.98				
<b>Output Frequency</b>	[Hz]		0 – 800				

Enclosure	IP 21, IP 54		E1				F1/F3				F2/F4								
	IP 00		E2																
			P315	P355	P400	P450	P500	P560	P630	P710	P800	P1M0							
<b>Typical Shaft Output at 400 V</b>	[kW]		315	355	400	450	500	560	630	710	800	1000							
<b>Typical Shaft Output at 460 V</b>	[HP]		450	500	550/600	600	700	750	900	1000	1200	1350							
<b>Output Current</b>																			
Continuous (3 x 380 – 400 V)	[A]		600	658	745	800	880	990	1120	1260	1460	1720							
Intermittent (3 x 380 – 400 V)	[A]		660	724	820	880	968	1089	1232	1386	1606	1892							
Continuous (3 x 441 – 480 V)	[A]		540	590	678	730	780	890	1050	1160	1380	1530							
Intermittent (3 x 441 – 480 V)	[A]		594	649	746	803	858	979	1155	1276	1518	1683							
<b>Output Power</b>																			
Continuous (at 400 V)	[kVA]		416	456	516	554	610	686	776	873	1012	1192							
Continuous (at 460 V)	[kVA]		430	4770	540	582	621	709	837	924	1100	1219							
<b>Max. Input Current</b>																			
Continuous (3 x 380 – 400 V)	[A]		590	647	733	787	857	964	1090	1227	1422	1675							
Continuous (3 x 441 – 480 V)	[A]		531	580	667	718	759	867	1022	1129	1344	1490							
<b>Max. cable size</b> Motor	[mm <sup>2</sup> ] ([AWG])		4 x 240 (3 x 500 mcm)				8 x 150 (8 x 300 mcm)				12 x 150 (12 x 300 mcm)								
<b>Max. cable size</b> Mains	[mm <sup>2</sup> ] ([AWG])										8 x 240 (8 x 500 mcm)								
<b>Max. cable size</b> Loadsharing	[mm <sup>2</sup> ] ([AWG])										4 x 120 (4 x 250 mcm)								
<b>Max. cable size</b> Brake	[mm <sup>2</sup> ] ([AWG])		1 x 185 (2 x 350 mcm)				4 x 185 (4 x 350 mcm)				6 x 185 (6 x 350 mcm)								
<b>Max. external pre-fuses</b>	[A]		700	900			1600		2000		2500								
<b>Estimated power loss at rated max. load – 400 V</b>	[W]		6706	7532	8677	9473	10161	11822	12514	14671	17294	19280							
<b>Estimated power loss at rated max. load – 460 V</b>	[W]		5930	6725	7820	8527	8877	10424	11595	13215	16228	16625							
<b>Weight</b>	IP 54	[kg]	263				270				1299		1541						
	IP 21	[kg]													1004				1246
	IP 00	[kg]																	-
<b>Efficiency</b>			0.98																
<b>Output Frequency</b>	[Hz]		0 – 800																

# 525 – 600 VAC and 525 – 690 VAC

Enclosure																					
IP 20 Chassis		A2							A3			B3			B4			C3		C4	
IP 21/NEMA 1		A5										B1			B2		C1			C2	
IP 55, IP 66/NEMA 12		PK75	P1K1	P1K5	P2K2	P3K0	P4K0	P5K5	P7K5	P11K	P15K	P18K	P22K	P30K	P37K	P45K	P55K	P75K	P90K		
<b>Typical Shaft Output</b>	[kW]	0.75	1.1	1.5	2.2	3	4	5.5	7.5	11	15	18.5	22	30	37	45	55	75	90		
<b>Output Current</b>																					
Continuous (3 x 525 – 550 V)	[A]	1.8	2.6	2.9	4.1	5.2	6.4	9.5	11.5	19	23	28	36	43	54	65	87	105	137		
Intermittent (3 x 525 – 550 V)	[A]	2.0	2.9	3.2	4.5	5.7	7.0	10.5	12.7	21	25	31	40	47	59	72	96	116	151		
Continuous (3 x 525 – 600 V)	[A]	1.7	2.4	2.7	3.9	4.9	6.1	9.0	11.0	18	22	27	34	41	52	62	83	100	131		
Intermittent (3 x 525 – 600 V)	[A]	1.9	2.6	3.0	4.3	5.4	6.7	9.9	12.1	20	24	30	37	45	57	68	91	110	144		
<b>Output Power</b>																					
Continuous (525 V AC)	[kVA]	1.7	2.5	2.8	3.9	5.0	6.1	9.0	11.0	18.1	21.9	26.7	34.3	41	51.4	61.9	82.9	100	130.5		
Continuous (575 V AC)	[kVA]	1.7	2.4	2.7	3.9	4.9	6.1	9.0	11.0	17.9	21.9	26.9	33.9	40.8	51.8	61.7	82.7	99.6	130.5		
<b>Max. cable size</b> IP 21/55/66 (mains, motor, brake)	[mm <sup>2</sup> ] ([AWG])	4 (10)							10 (7)			35 (2)			50 (1/0)		95 (4/0)	120 (250 MCM)			
<b>Max. cable size</b> IP 20 (mains, motor, brake)	[mm <sup>2</sup> ] ([AWG])	4 (10)							10 (7)			35 (2)		50 (1/0)			95 (4/0)	150 (250 MCM) <sup>1)</sup>			
<b>Max. cable size mains</b> With mains disconnect switch included	[mm <sup>2</sup> ] ([AWG])	4 (10)							16 (6)						35 (2)		70 (3/0)	185 (kcmil 350)			
<b>Max. Input Current</b>																					
Continuous (3 x 525 – 600 V)	[A]	1.7	2.4	2.7	4.1	5.2	5.8	8.6	10.4	17.2	20.9	25.4	32.7	39	49	59	78.9	95.3	124.3		
Intermittent (3 x 525 – 600 V)	[A]	2.2	2.7	3.0	4.5	5.7	6.4	9.5	11.5	19	23	28	36	43	54	65	87	105	137		
<b>Max. pre-fuses</b>	[A]	10			20			32			63			80	100	125	160	250	250		
<b>Environment</b>																					
<b>Estimated power loss at rated max. load</b>	[W]	35	50	65	92	122	145	195	261	300	400	475	525	700	750	850	1100	1400	1500		
<b>Weight</b>																					
IP 20	[kg]	6.5							6.6			12			23.5			35	50		
IP 21, IP 55, IP 66	[kg]	13.5							14.2			23			27			45	65		
<b>Efficiency</b>		0.97									0.98										

1) With brake and load sharing 95 (4/0)

Enclosure									
IP 21/NEMA 1, IP 55/NEMA 12				B2			C2		
				P11K	P15K	P18K	P22K	P30K	P37K
<b>Typical Shaft Output</b>	[kW]			11	15	18.5	22	30	37
<b>Typical Shaft Output</b>	[HP]			10	16.4	20.1	24	33	40
<b>Output Current</b>									
Continuous (3 x 525 – 550 V)	[A]			14	19	23	28	36	43
Intermittent (3 x 525 – 550 V)	[A]			15.4	20.9	25.3	30.8	39.6	47.3
Continuous (3 x 551 – 690 V)	[A]			13	18	22	27	34	41
Intermittent (3 x 551 – 690 V)	[A]			14.3	19.8	24.2	29.7	37.4	45.1
<b>Output Power</b>									
Continuous (550 V AC)	[kVA]			13.3	18.1	21.9	26.7	34.3	41
Continuous (575 V AC)	[kVA]			12.9	17.9	21.9	26.9	33.8	40.8
Continuous (690 V AC)	[kVA]			15.5	21.5	26.3	32.3	40.6	49
<b>Max. cable size</b> (mains, motor, brake)	[mm <sup>2</sup> ] ([AWG])	35 (1/0)							
<b>Max. Input Current</b>									
Continuous (3 x 525 – 690 V)	[A]			15	19.5	24	29	36	49
Intermittent (3 x 525 – 690 V)	[A]			16.5	21.5	26.4	31.9	39.6	53.9
<b>Max. pre-fuses</b>	[A]			60					150
<b>Environment</b>									
<b>Estimated power loss at rated max. load</b>	[W]			201	285	335	375	430	592
<b>Weight</b>									
IP 21, IP 55	[kg]	27							
<b>Efficiency</b>		0.98							

# 525 – 690 VAC

Enclosure	IP 21, IP 54		D1						D2			
	IP 00		D3						D4			
			P45K	P55K	P75K	P90K	P110	P132	P160	P200	P250	
<b>Typical Shaft Output at 550 V</b>	[kW]		37	45	55	75	90	110	132	160	200	
<b>Typical Shaft Output at 575 V</b>	[HP]		50	60	75	100	125	150	200	250	300	
<b>Typical Shaft Output at 690 V</b>	[kW]		45	55	75	90	110	132	160	200	250	
<b>Output Current</b>												
Continuous (at 3 x 525 – 550 V)	[A]		56	76	90	113	137					
Continuous (at 550 V)	[A]							162	201	253	303	
Intermittent (60 sec overload) (at 550 V)	[A]		62	84	99	124	151	178	221	278	333	
Continuous (at 3 x 551 – 690 V)	[A]		54	73	86	108	131					
Continuous (at 575/690 V)	[A]							155	192	242	290	
Intermittent (60 sec overload) (at 575/690 V)	[A]		59	80	95	119	144	171	211	266	319	
<b>Output Power</b>												
Continuous (at 550 V)	[kVA]		53	72	86	108	131	154	191	241	289	
Continuous (at 575 V)	[kVA]		54	73	86	108	130	154	191	241	289	
Continuous (at 690 V)	[kVA]		65	87	103	129	157	185	229	289	347	
<b>Max. Input Current</b>												
Continuous (at 550 V)	[A]		60	77	89	110	130	158	198	245	299	
Continuous (at 575 V)	[A]		58	74	85	106	124	151	189	234	286	
Continuous (at 690 V)	[A]		58	77	87	109	128	155	197	240	296	
<b>Max. cable size</b> Mains, motor, load share and brake	[mm <sup>2</sup> ] ([AWG])		2 x 70 (2 x 2/0)				2 x 70 (2 x 2/0)			2 x 150 (2 x 300 mcm)		
<b>Max. external pre-fuses</b>	[A]		125	160	200	200	250	315	350	350	400	
<b>Estimated power loss at rated max. load – 600 V</b>	[W]		1398	1645	1827	2157	2533	2963	3430	4051	4867	
<b>Estimated power loss at rated max. load – 690 V</b>	[W]		1458	1717	1913	2262	2662	3430	3612	4292	5156	
<b>Weight</b>	IP 21, IP 54	[kg]	96						104	125	136	
	IP 00	[kg]	82						91	112	123	
<b>Efficiency</b>			0.97				0.98					
<b>Output Frequency</b>	[Hz]		0 – 600									

Enclosure	IP 54/NEMA 12		D2		E1			F1/F3 <sup>1)</sup>			F2/F4 <sup>1)</sup>				
	IP 21/NEMA 1		D4		E2			-			-				
			P315	P400	P450	P500	P560	P630	P710	P800	P900	P1M0	P1M2	P1M4	
<b>Typical Shaft Output at 550 V</b>	[kW]		250	315	355	400	450	500	560	670	750	850	1000	1100	
<b>Typical Shaft Output at 575 V</b>	[HP]		350	400	450	500	600	650	750	950	1050	1150	1350	1500	
<b>Typical Shaft Output at 690 V</b>	[kW]		315	400	450	500	560	630	710	800	900	1000	1200	1400	
<b>Output Current</b>															
Continuous (3 x 550 V)	[A]		360	418	470	523	596	630	763	889	988	1108	1317	1479	
Intermittent (3 x 550 V)	[A]		396	460	517	575	656	693	839	978	1087	1219	1449	1627	
Continuous (3 x 690 V)	[A]		344	400	450	500	570	630	730	850	945	1060	1260	1415	
Intermittent (3 x 690 V)	[A]		378	440	495	550	627	693	803	935	1040	1166	1386	1557	
<b>Output Power</b>															
Continuous (at 550 VAC)	[kVA]		343	398	448	498	568	600	727	847	941	1056	1255	1409	
Continuous (at 575 VAC)	[kVA]	627													
Continuous (at 690 VAC)	[kVA]		411	478	538	598	681	753	872	1016	1129	1267	1506	1691	
<b>Max. Input Current</b>															
Continuous (3 x 550 V)	[A]		355	408	434	453	504	574	607	743	866	962	1079	1282	1440
Continuous (3 x 575 V)	[A]		339	390		482	549	607	711	828	920	1032	1227	1378	
Continuous (3 x 690 V)	[A]		352	400		482	549	607	711	828	920	1032	1227	1378	
<b>Max. cable size</b> Mains	[mm <sup>2</sup> ] ([AWG])		2 x 185 (2 x 300 mcm)		4 x 240 (4 x 500 mcm)				8 x 240 (8 x 500 mcm)						
<b>Max. cable size</b> Motor	[mm <sup>2</sup> ] ([AWG])								8 x 150 (8 x 300 mcm)			12 x 150 (12 x 300 mcm)			
<b>Max. cable size</b> Brake	[mm <sup>2</sup> ] ([AWG])				2 x 185 (2 x 350 mcm)				4 x 185 (4 x 350 mcm)			6 x 185 (6 x 350 mcm)			
<b>Max. mains pre-fuses</b>	[A]		500	550	700	900	2000				2500				
<b>Estimated power loss at rated max. load – 600 VAC</b>	[W]		4308	4757	4974	5622	7018	7792	8933	10310	11692	12909	15358	17602	
<b>Estimated power loss at rated max. load – 690 VAC</b>	[W]		4486	4925	5128	5794	7221	8017	9212	10659	12080	13305	15865	18173	
<b>Weight</b>	IP 21, IP 54	[kg]	151	165	263	272	313	1004			1246		1280		
	IP 00	[kg]	138	151	221	236	277	-							
<b>Efficiency</b>			0.98												
<b>Output Frequency</b>	[Hz]		0 – 500												

1) Adding the F-enclosure option cabinet (resulting in the F3 and F4 enclosure sizes) adds 295 kg to the estimated weight.

# Dimensions VLT® AQUA Drive

In mm

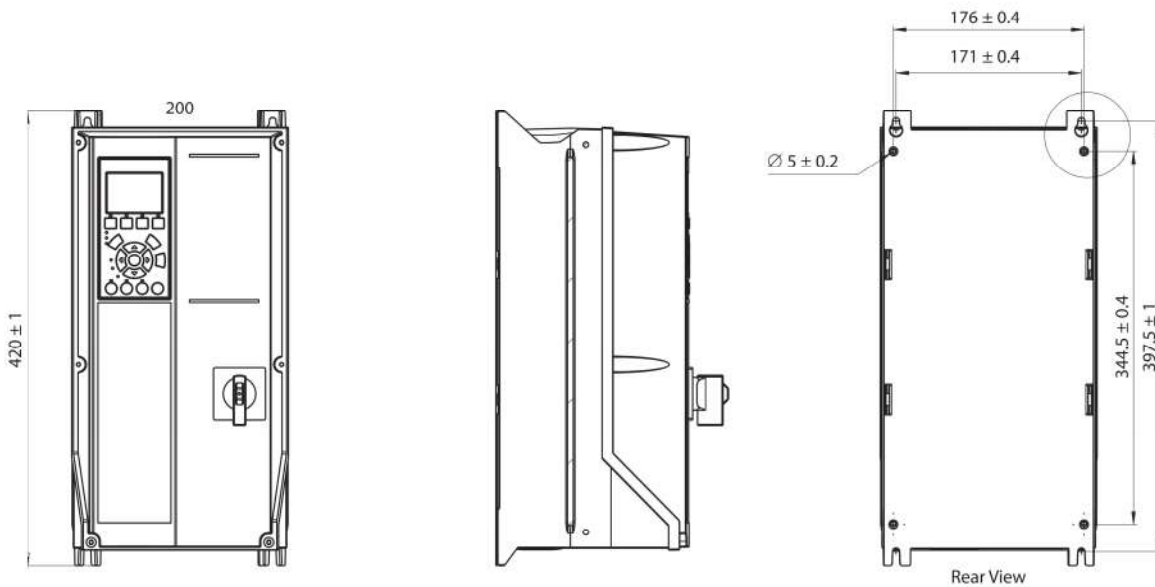
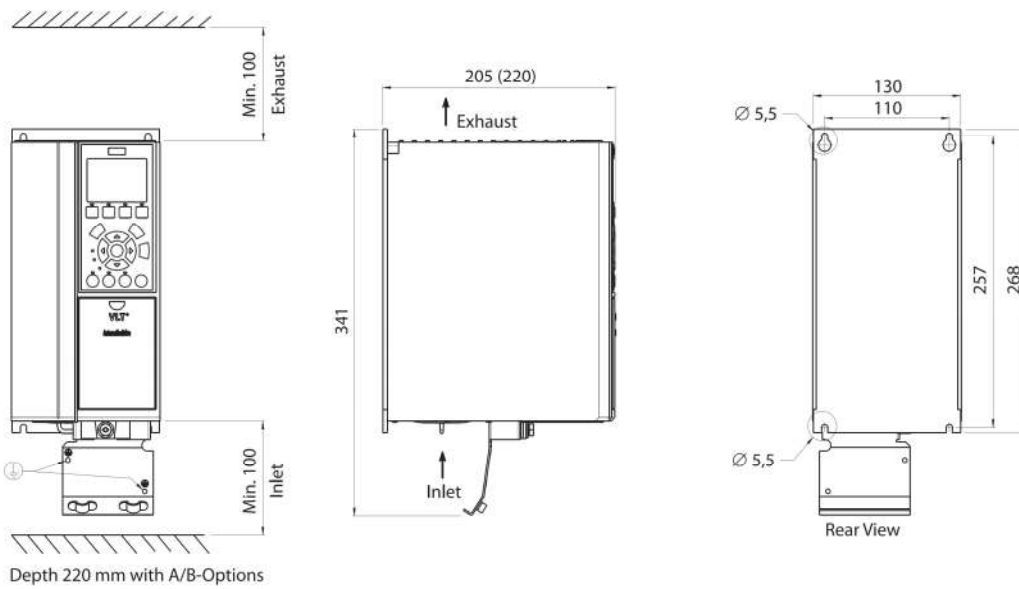
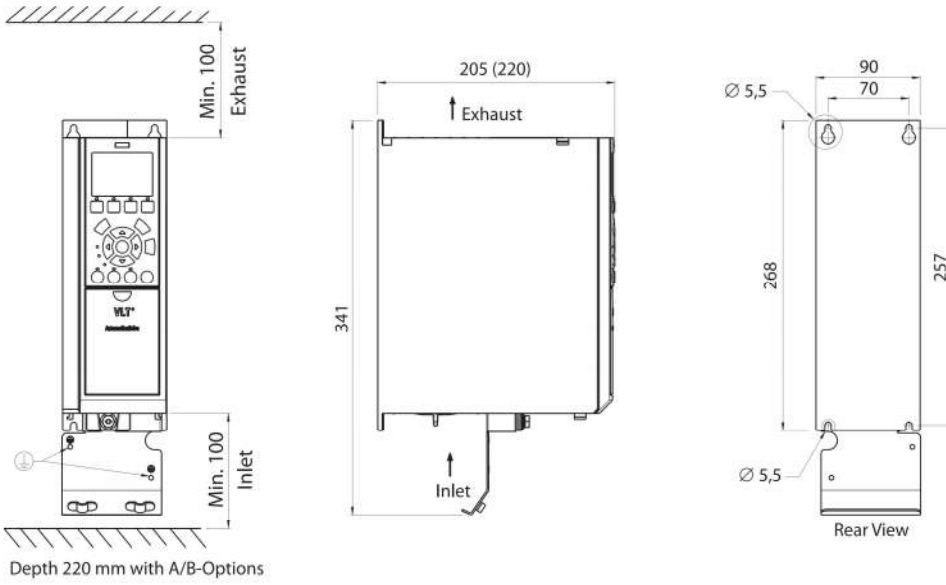

A2 Enclosures

A3 Enclosures

A4 Enclosures

# Dimensions VLT® AQUA Drive

In mm

## A5 Enclosures

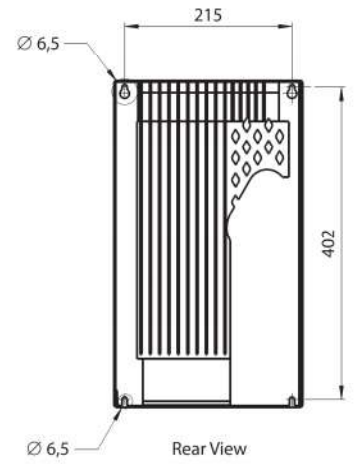
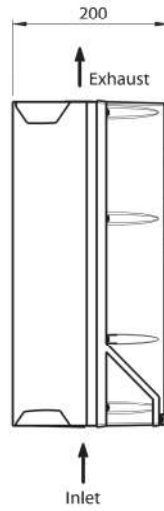
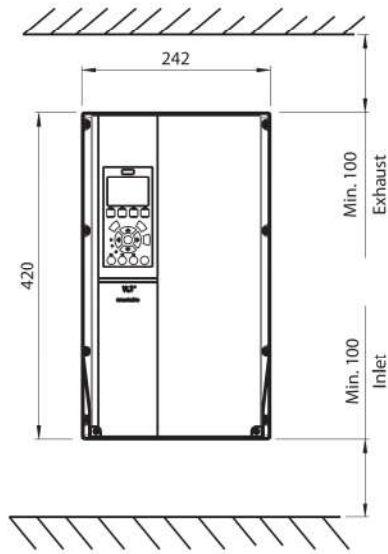

## B1 Enclosures

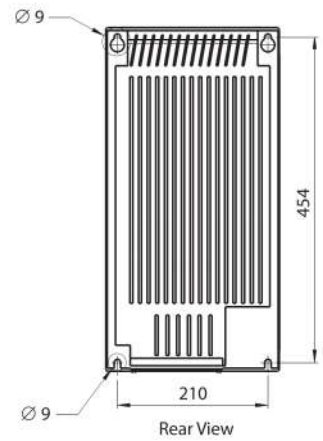
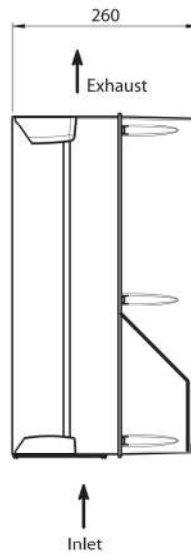
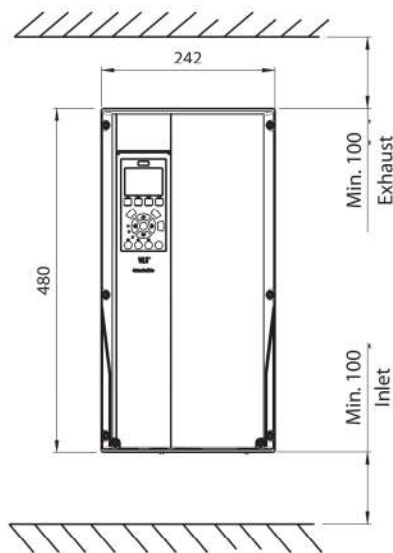

## B2 Enclosures

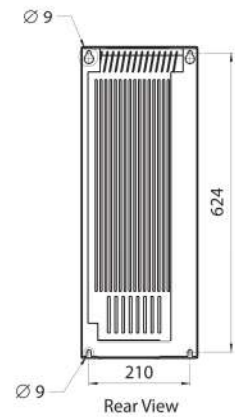
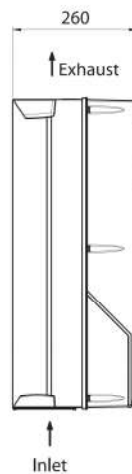
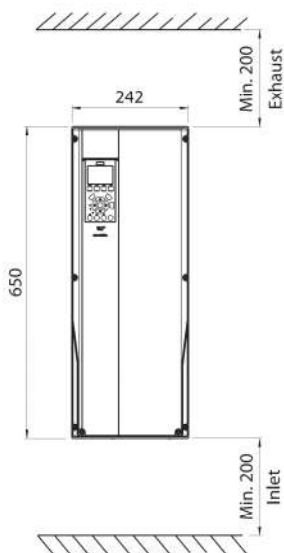



# Dimensions VLT® AQUA Drive

In mm

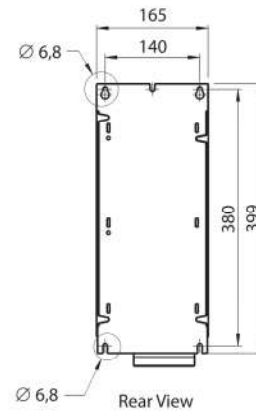
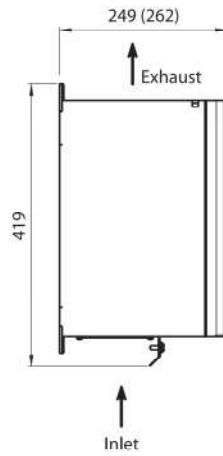
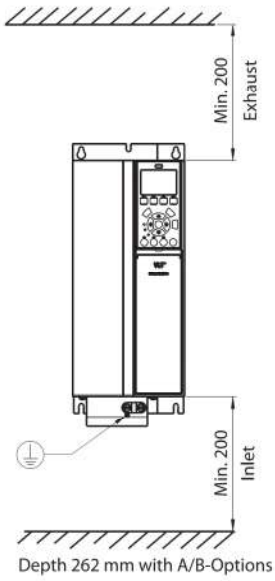

B3 Enclosures

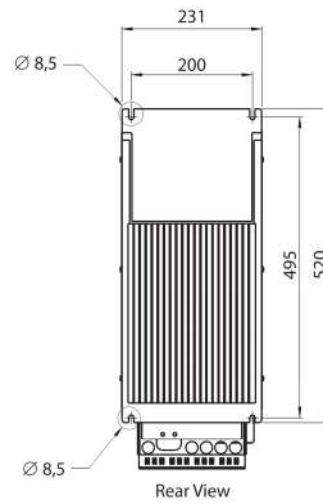
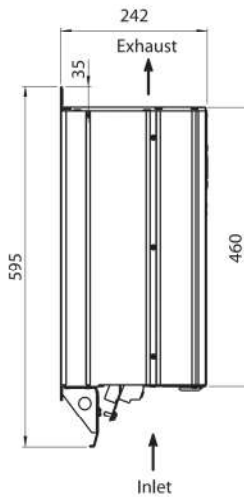
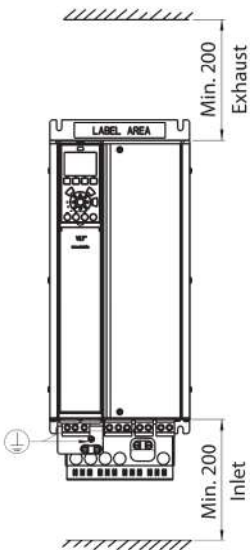

B4 Enclosures

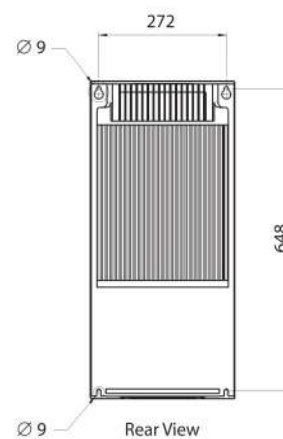
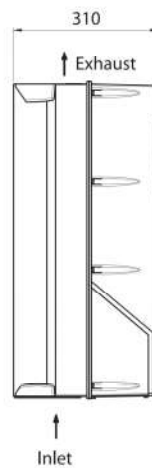
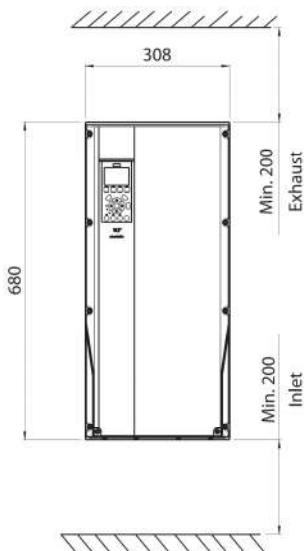

C1 Enclosures

# Dimensions VLT® AQUA Drive

In mm

## C2 Enclosures

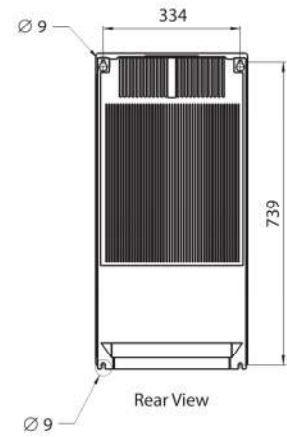
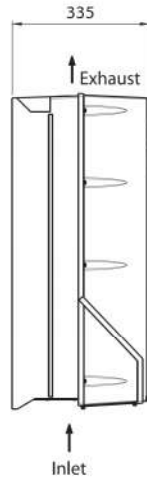
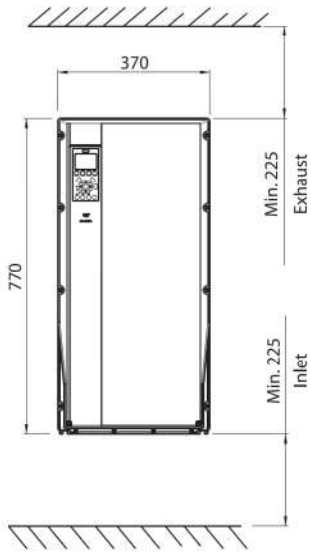

## C3 Enclosures

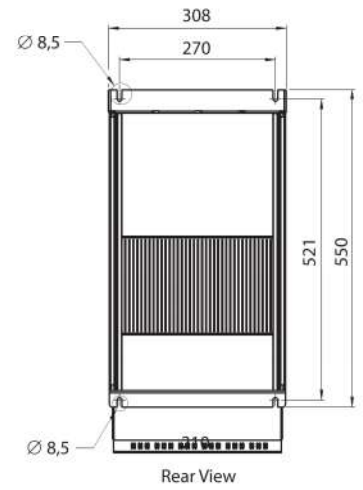
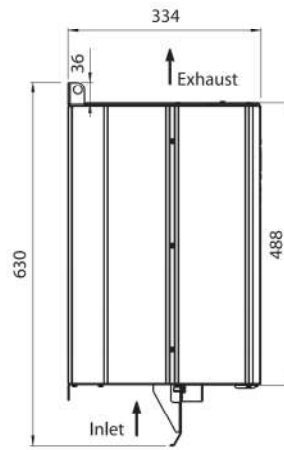
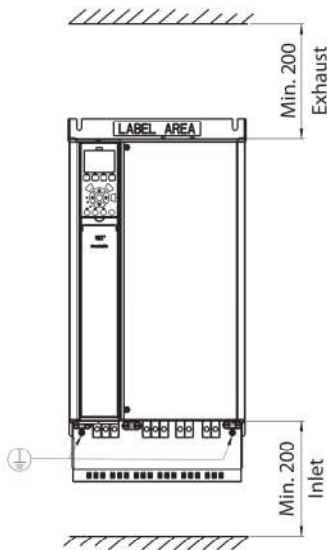

## C4 Enclosures

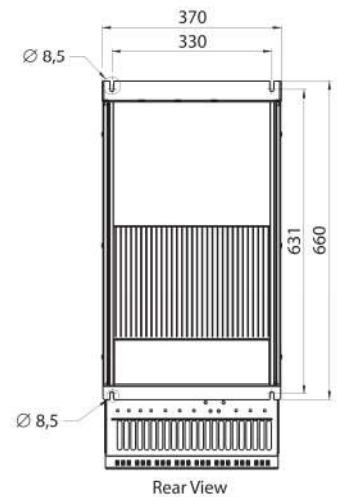
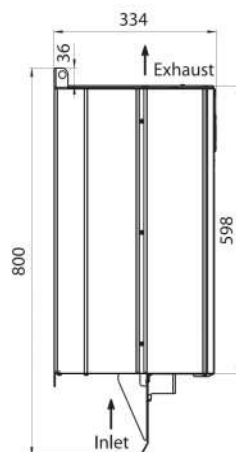
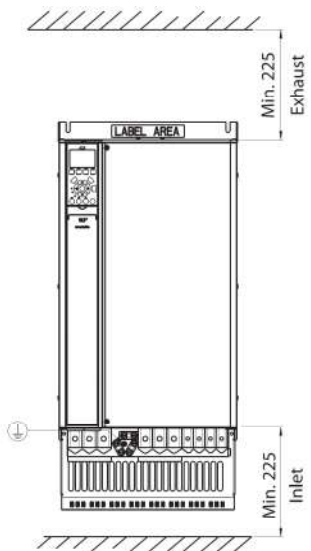

# Dimensions VLT® AQUA Drive

In mm

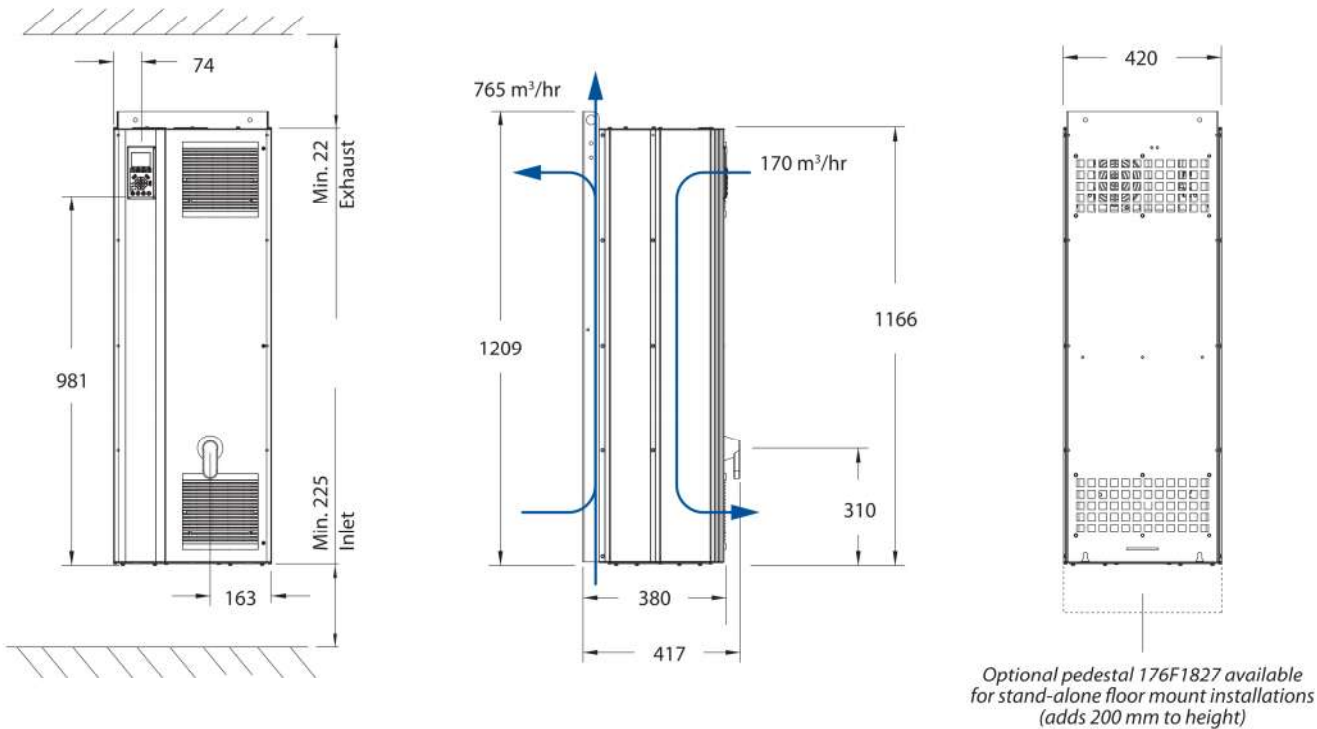

D1 Enclosures (Floor- or cabinet Mount)

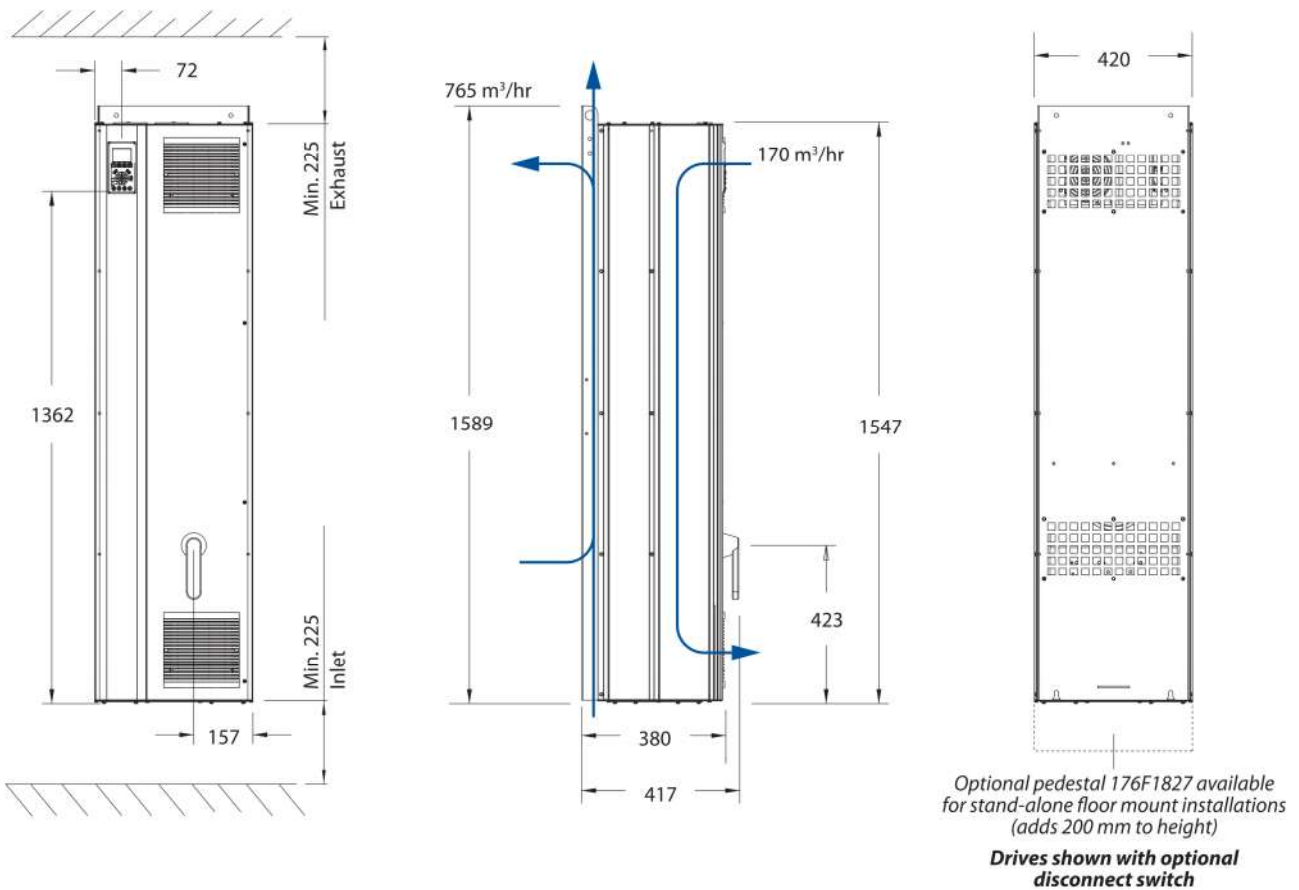

D2 Enclosures (Floor- or cabinet Mount)

# Dimensions VLT® AQUA Drive

In mm

## D3 Enclosures (Cabinet Mount)

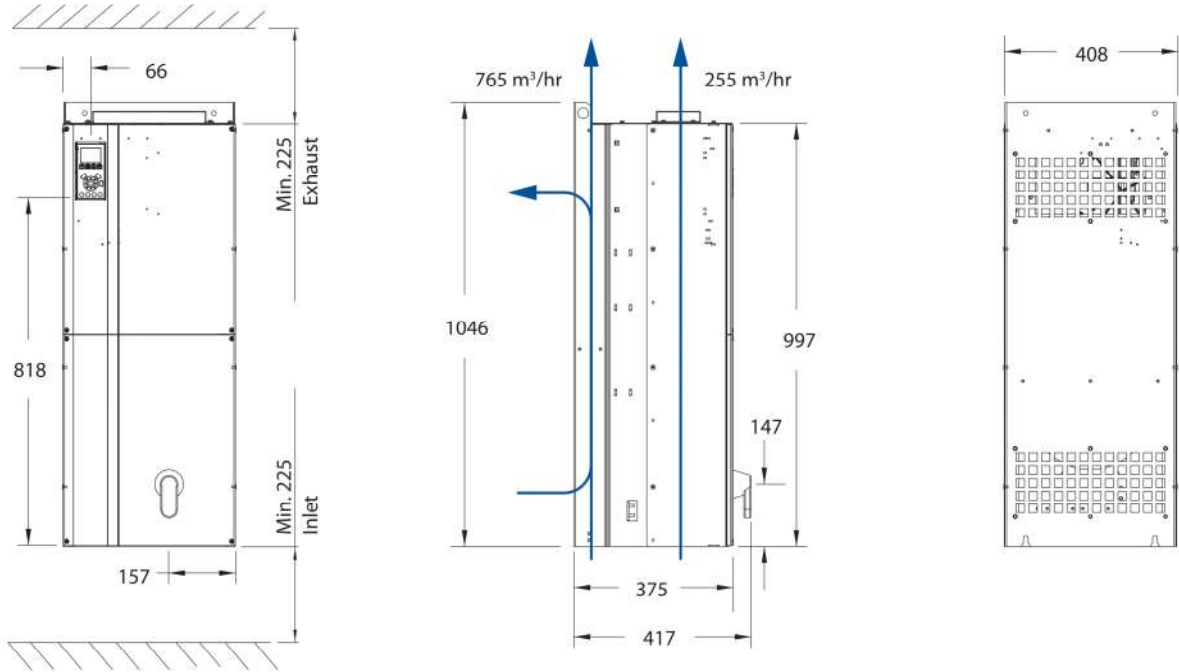

## D4 Enclosures (Cabinet Mount)

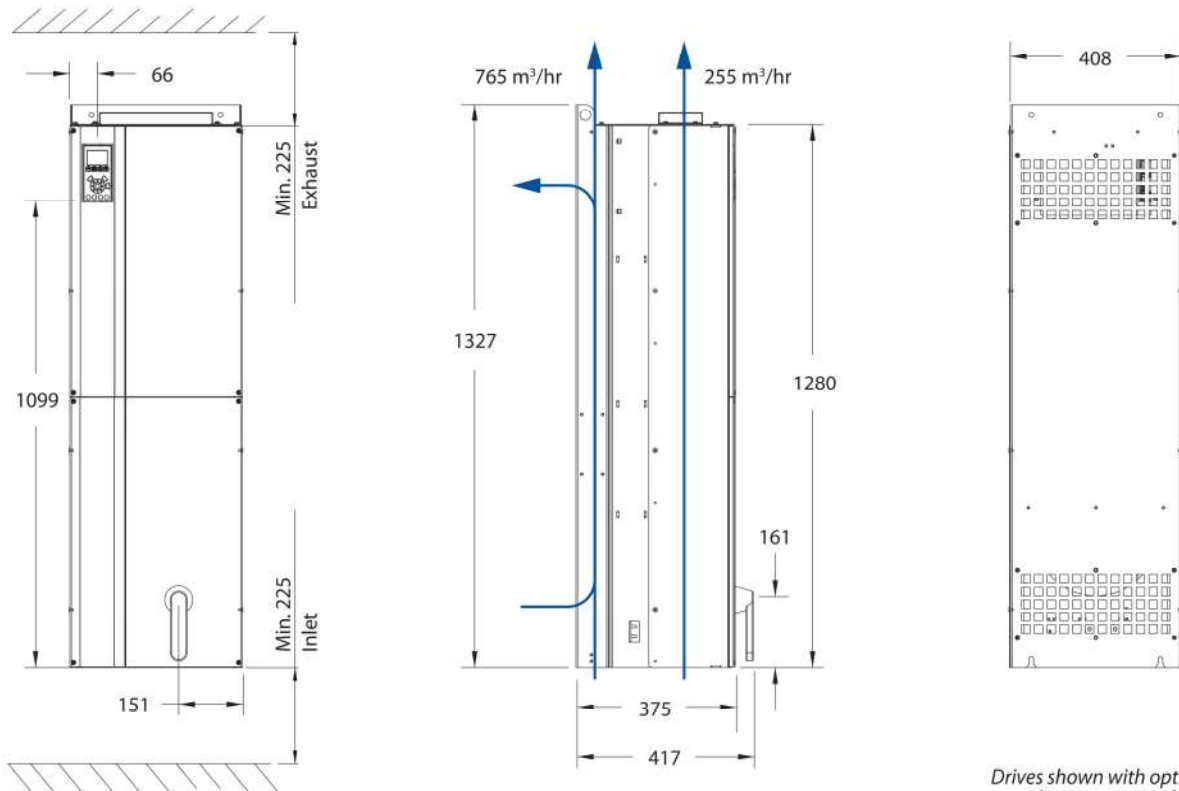

Drives shown with optional disconnect switch

# Dimensions VLT® AQUA Drive

In mm

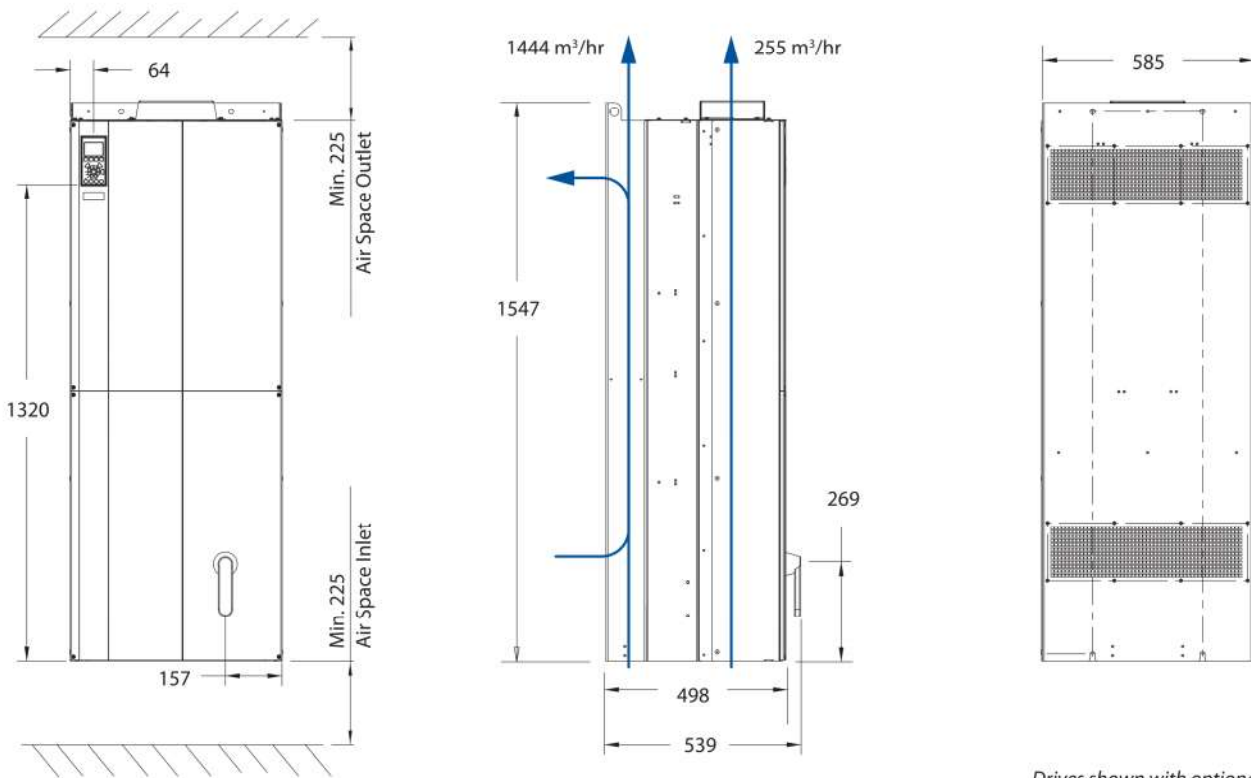
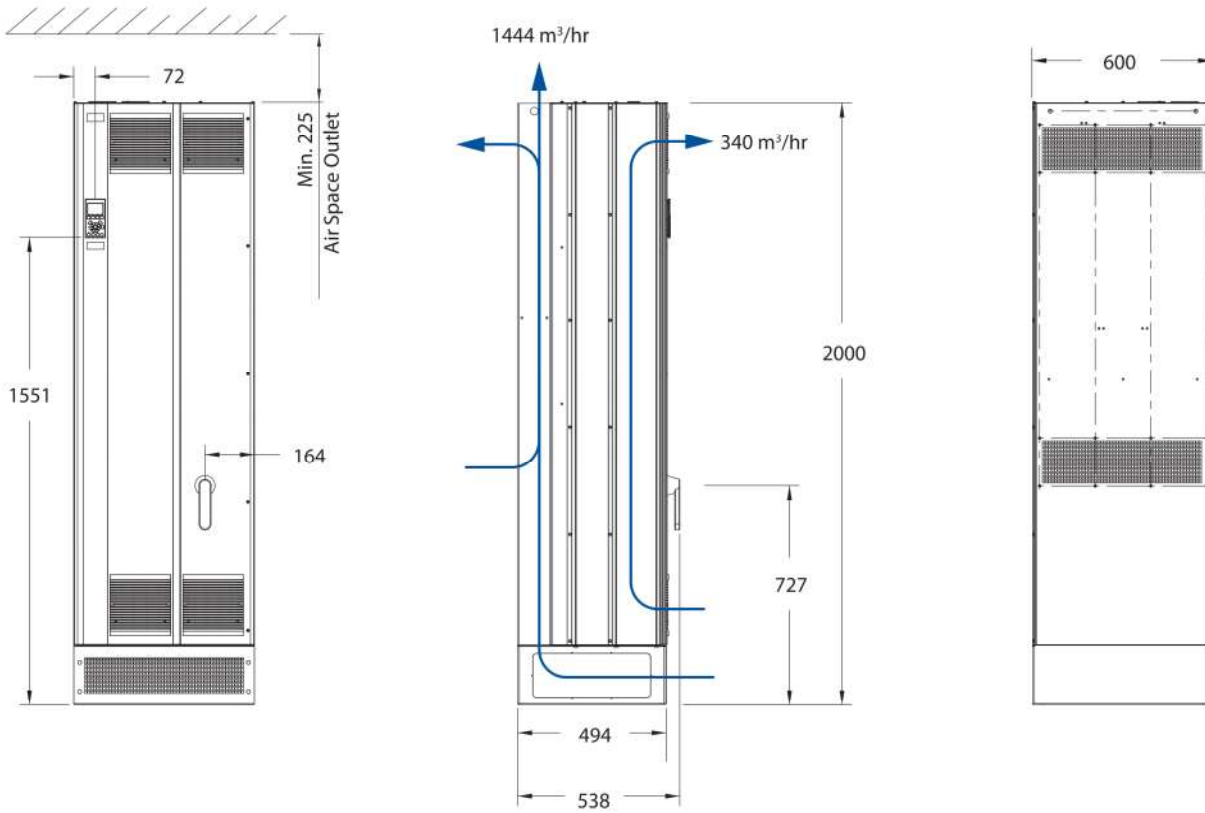

Drives shown with optional disconnect switch

E1 Enclosures (Floor Mount)

E2 Enclosures (Cabinet Mount)

# Dimensions VLT® AQUA Drive

In mm

## F1 + F3 Enclosures (Floor Mount)

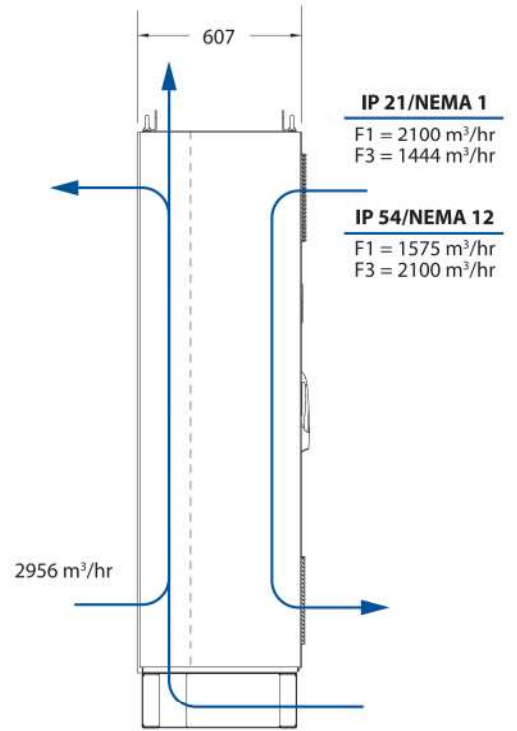
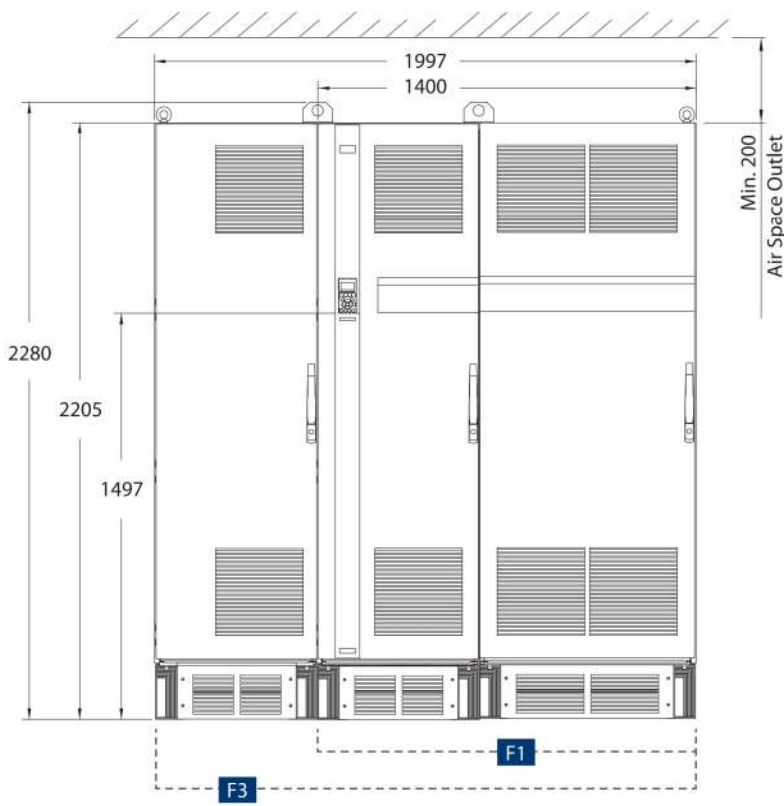

## F2 + F4 Enclosures (Floor Mount)

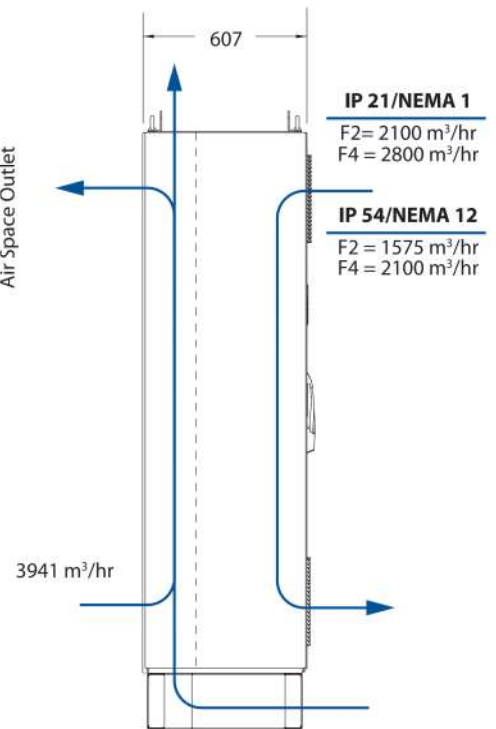
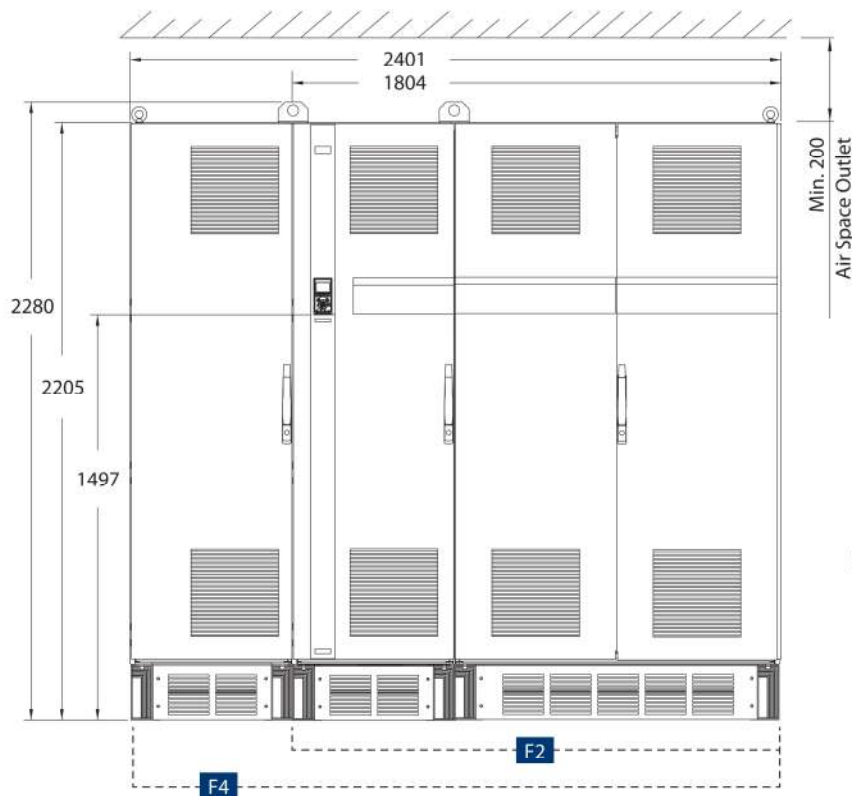

# VLT® AQUA Drive Options

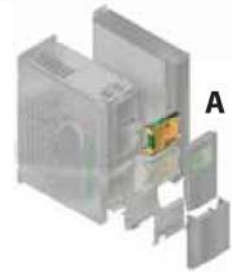

Typecode Position

## VLT® PROFIBUS DP V1 MCA 101

- PROFIBUS DP V1 gives you wide compatibility, a high level of availability, support for all major PLC vendors, and compatibility with future versions
- Fast, efficient communication, transparent installation, advanced diagnosis and parameterisation and auto-configuration of process data via GSD-file
- A-cyclic parameterisation using PROFIBUS DP V1, PROFIdrive or Danfoss FC profile state machines, PROFIBUS DP V1, Master Class 1 and 2

Ordering number 130B1100 uncoated – 130B1200 coated (Class 3C3/IEC 60721-3-3)



13

## VLT® DeviceNet MCA 104

- This modern communications model offers key capabilities that let you effectively determine what information is needed and when
- You will also benefit from ODVA's strong conformance testing policies, which ensure that products are interoperable

Ordering number 130B1102 uncoated – 130B1202 coated (Class 3C3/IEC 60721-3-3)



13

## VLT® PROFINET RT MCA 120

The VLT® PROFINET Option offers connectivity to PROFINET based networks via the PROFINET Protocol. The option is able to handle a single connection with an Actual Packet Interval down to 1 ms in both directions, positioning it among the fastest performing PROFINET devices in the market.

- Built-in web server for remote diagnosis and reading out of basic drive parameters
- An e-mail notifiicator can be configured for sending an e-mail message to one or several receivers, if certain warnings or alarms occur, or have cleared again
- TCP/IP for easy access to Drive configuration data from MCT 10
- FTP (File Transfer Protocol) file up- and download
- Support of DCP (discovery and configuration protocol)



13

## VLT® EtherNet IP MCA 121

EtherNet will become the future standard for communication at the factory floor. The EtherNet Option is based on the newest technology available for the Industrial use and handles even the most demanding requirements. EtherNet/IP extends commercial off-the-shelf EtherNet to the Common Industrial Protocol (CIP™) – the same upper-layer protocol and object model found in DeviceNet. The VLT® MCA 121 offers advanced features as:

- Built-in high performance switch enabling line-topology, and eliminating the need for external switches
- Advanced switch and diagnoses functions
- Built-in web server
- E-mail client for service notification



13

## VLT® Modbus TCP MCA 122

The VLT® Modbus Option offers connectivity to Modbus TCP based networks, such as Groupe Schneider PLC system via the Modbus TCP Protocol. The option is able to handle a single connection with an Actual Packet Interval down to 5 ms in both directions, positioning it among the fastest performing Modbus TCP devices in the market.

- Built-in web-server for remote diagnosis and reading out basic drive parameters
- An e-mail notifiicator can be configured for sending an e-mail message to one or several receivers, if certain warnings or alarms occur, or have cleared again
- Two Ethernet ports with built-in switch
- FTP (File Transfer Protocol) file up- and download
- Protocol – automatic – IP address configuration



13

# VLT® AQUA Drive Options

Typecode Position		
14-B		<p><b>VLT® General Purpose I/O MCB 101</b></p> <p>The I/O option offers an extended number of control inputs and outputs.</p> <ul style="list-style-type: none"> <li>• 3 digital inputs 0-24 V; Logic '0' &lt; 5 V; Logic '1' &gt; 10V</li> <li>• 2 analogue inputs 0-10 V; Resolution 10 bit plus sign</li> <li>• 2 digital outputs NPN/PNP push pull</li> <li>• 1 analogue output 0/4-20 mA</li> <li>• Spring loaded connection</li> <li>• Separate parameter settings</li> </ul> <p>Ordering number 130B1125 uncoated – 130B1212 coated (Class 3C3/IEC 60721-3-3)</p>
14-B		<p><b>VLT® Relay Option MCB 105</b></p> <p>Lets you extend relay functions with 3 additional relay outputs.</p> <p>Max. terminal load:</p> <ul style="list-style-type: none"> <li>• AC-1 Resistive load ..... 240 V AC 2 A</li> <li>• AC-15 Inductive load @cos φ 0.4 ..... 240 V AC 0.2 A</li> <li>• DC-1 Resistive load ..... 24 V DC 1 A</li> <li>• DC-13 Inductive load @cos φ 0.4 ..... 24 V DC 0.1 A</li> </ul> <p>Min. terminal load:</p> <ul style="list-style-type: none"> <li>• DC 5 V ..... 10 mA</li> <li>• Max switch rate at rated load/min. load ..... 6 min<sup>-1</sup>/20 sec<sup>-1</sup></li> </ul> <p>Ordering number 130B1110 uncoated – 130B1210 coated (Class 3C3/IEC 60721-3-3)</p>
14-B		<p><b>VLT® Analog I/O Option MCB 109</b></p> <p>This analogue input/output option is easily fitted in the frequency converter for upgrading to advanced performance and control using the additional in/outputs. This option also upgrades the frequency converter with a battery back-up supply for the clock built into the frequency converter. This provides stable use of all frequency converter clock functions as timed actions etc.</p> <ul style="list-style-type: none"> <li>• 3 analogue inputs, each configurable as both voltage and temperature input</li> <li>• Connection of 0-10 V analogue signals as well as PT1000 and NI1000 temperature inputs</li> <li>• 3 analogue outputs each configurable as 0-10 V outputs</li> <li>• Incl. back-up supply for the standard clock function in the frequency converter</li> </ul> <p>The back-up battery typically lasts for 10 years, depending on environment.</p> <p>Ordering number 130B1143 uncoated – 130B1243 coated (Class 3C3/IEC 60721-3-3)</p>
14-B		<p><b>VLT® Sensor Input Option MCB 114</b></p> <p>The option protects the motor from being overheated by monitoring the bearings and windings temperature in the motor. The limits as well as the action are adjustable and the individual sensor temperature is visible as a read out in the display or by field bus.</p> <ul style="list-style-type: none"> <li>• Protects the motor from overheating</li> <li>• Three self-detecting sensor inputs for 2 or 3 wire PT100/PT1000 sensors</li> <li>• One additional analogue input 4-20 mA</li> </ul>
14-B		<p><b>VLT® Extended Cascade Controller MCO 101</b></p> <p>Easily fitted and upgrades the built-in cascade controller to operate more pumps and more advanced pump control in master/follower mode.</p> <ul style="list-style-type: none"> <li>• Up to 6 pumps in standard cascade setup</li> <li>• Up to 6 pumps in master/follower setup</li> <li>• Technical specification: See MCB 105 Relay Option</li> </ul>
16-C		<p><b>VLT® Advanced Cascade Controller MCO 102</b></p> <p>Easily fitted and upgrades the built-in cascade controller to operate up to 8 pumps and more advanced pump control in master/follower mode.</p> <p>The same cascade controller hardware goes for for the entire power range up to 1.4 MW.</p> <ul style="list-style-type: none"> <li>• Up to 9 pumps in standard cascade setup</li> <li>• Up to 8 pumps in master/follower setup</li> </ul>

Installation of options is a matter of plug-and-play



# VLT® AQUA Drive Options

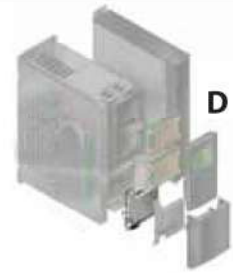

Typecode Position

## VLT® 24 V DC Supply Option MCB 107

The option is used to connect an external DC supply to keep the control section and any installed option active when mains power is down.

- Input voltage range 24 V DC +/- 15% (max. 37 V in 10 sec.)
- Max. input current ..... 2.2 A
- Max. cable length ..... 75 m
- Input capacitance load ..... < 10 uF
- Power-up delay ..... < 0.6 s
- Easy to install in drives in existing machines
- Keeps the control board and options active during power cuts
- Keeps fieldbuses active during power cuts

Ordering number 130B1108 uncoated – 130B1208 coated (Class 3C3/IEC 60721-3-3)



18



Typecode Position

## LCP 102 Graphical Local Control Panel

- Multi-language display
- Status messages
- Quick Menu for easy commissioning
- Parameter setting and explanation of parameter function
- Adjustment of parameters
- Full parameter backup and copy function
- Alarm logging
- Info button – explains the function of the selected item on display
- Hand-operated start/stop, or automatic mode selection
- Reset function
- Trend graph

Ordering number 130B1107



7

## LCP 101 Numerical Local Control Panel

The numerical control panel offers an excellent MMI interface to the drive.

- Status messages
- Quick menu for easy commissioning
- Parameter setting and adjustment
- Hand-operated start/stop function or automatic mode select
- Reset function

Ordering number 130B1124



7

## LCP Panel Mounting Kit

For easy installation of the LCP 101 and LCP 102 in e.g. a cabinet.

- IP65 (front)
- Thumb screws for tool-free installation
- Incl. 3 meters of cables in industry quality (also available separately)
- With or without LCP operating unit
- Each time easy to install

Ordering number 130B1117 (Mounting kit for all LCP's including fasteners, 3 m cable and gasket)

Ordering number 130B1113 (Incl. graphical LCP, fasteners, 3 m cable and gasket)

Ordering number 130B1114 (Incl. numerical LCP, fasteners and gasket)

Ordering number 130B1129 (LCP front mounting IP55/IP66) – Ordering number 175Z0929 (cable only)

Ordering number 130B1170 (Panel Mounting Kit for all LCP w.o. cable)



# VLT® AQUA Drive Accessories



## Profibus Adapter Sub-D9 Connector

The adapter makes linking of fieldbus connections pluggable. For use with option A.

- Option to use prefabricated Profibus cabling
- For retrofit

Ordering number 130B1112 for frame size A, B and C  
Ordering number 176F1742 for frame D and E



## Screw terminals

Screw terminals as an alternative to the standard springloaded terminals.

- Pluggable
- Terminal name is described

Ordering number 130B1116



## IP 21/Type 12 (NEMA1) Kit

The IP 21/Type 12 (NEMA1) kit is used for installation of VLT® drives in dry environments.

The enclosure kits are available for frame sizes A1, A2, A3, B3, B4, C3 and C4

- Supports VLT® drives from 1.1 to 90 kW
- Used on standard VLT® drives with or without mounted option modules
- IP 41 on top side
- PG 16 and PG 21 holes for glands

130B1122 for frame size A2, 130B1123 for frame size A3, 130B1187 for frame size B3, 130B1189 for frame size B4, 130B1191 for frame size C3, 130B1193 for frame size C4



## Kit for panel through mount

Mounting kit for external cooling of the heatsink for appliances with A5, B1, B2, C1 and C2 housing.

- The air conditioned installation space can be reduced.
- Additional cooling may be omitted
- No contamination of electronics by forced ventilation
- Facilitates integrated assembly
- Reduced cabinet depth/less space



## VLT® Brake Resistors

Energy generated during braking is absorbed by the resistors, protecting electrical components from heating up. Danfoss brake resistors cover the full power range.

- Quick braking of heavy loads
- Braking energy is only absorbed into the brake resistor
- External mounting makes it possible to use the generated heat
- All necessary approvals are available



## USB Extension

USB extension for IP 55 and IP 66 enclosures. Makes the USB connector available outside the drive. The USB extension is designed for mounting in a cable gland in the bottom of the drive, which makes PC communication very easy even in drives with high IP rating.

USB extension for A5-B1, D and E enclosures, 350 mm cable, ordering number 130B1155  
USB extension for B2-C enclosures, 650 mm cable, ordering number 130B1156  
USB extension for F enclosures, ordering number 176F1784

Please refer to the product and design manuals for selection and dimensioning

# VLT® AQUA Drive Accessories



## VLT® Advanced Harmonic Filters – AHF 005/AHF 010

The Danfoss Advanced Harmonic Filters have been specially designed to match the Danfoss frequency converters. The solution is available in two variants, a AHF 005 and AHF 010 and connected in front of a Danfoss frequency converter, the harmonic current distortion generated back to the mains is reduced to 5% and 10% Total Harmonic Current Distortion at full load.

- Electrically matched to the individual VLT® FC-drives
- >98% efficiency
- Side-by-side mounting with VLT®
- Optimized for mounting in panels
- Easy to use in retrofit applications
- Easy commissioning
- Robust solution that require no routine maintenance
- IP 00 and IP 20 (IP 21/NEMA 1 kit optional)



## VLT® Sine-Wave Filters – MCC 101

Sine-Wave filters are placed between the frequency converter and the motor.

They are low-pass filters that suppress the switching frequency component from the frequency converter and smooth out the phase-to-phase output voltage of the frequency converter to become sinusoidal. This reduces the motor insulation stress, bearing currents and eliminates the switching acoustic noise from the motor.

- Mechanically and electrically matched to the individual VLT® FC-drives
- Eliminates over-voltages and voltage spikes caused by cable reflections
- Protects the motor insulation against premature aging
- Reduces electromagnetic interference by eliminating pulse reflection caused by current ringing in the motor cable. This allows the use of unshielded motor cables in some applications.
- Reduces high frequent losses in motor
- Applications with longer motor cables (>150 m)
- Side-by-side mounting with VLT®
- IP 00 and IP 20 (IP 23 above 115 A)



## VLT® du/dt Filters – MCC 102

du/dt filters are placed between the frequency converter and the motor. They are differential-mode filters which reduce motor terminal phase-to-phase peak voltages spikes and reduce the rise time to a level that lowers the stress on the insulation of motor windings. du/dt filters are smaller, weigh less and have a lower price compared to sine-wave filters.

- Mechanically and electrically matched to the individual VLT® FC-drives
- Due to low voltage drop du/dt filters are ideal for highly dynamic applications with flux vector regulation
- Dampen the ringing oscillations at the motor terminals and reduces risk of double pulsing and voltage peaks
- Applications with short motor cables (up to 150 m)
- Side-by-side mounting with VLT®
- IP 00 and IP 20 (IP 23 above 115 A)



## VLT® Common Mode Filters – MCC 105

Common mode filters are placed between the frequency converter and the motor. They are nano-crystalline cores that mitigate high frequency noise in the motor cable (shielded or unshielded) and reduce bearing currents in the motor.

- Extends motor bearing lifetime
- Can be combined with du/dt and Sine-Wave filters
- Reduces radiated emissions from the motor cable
- Easy to install – no adjustments necessary
- Oval shaped – allows mounting inside the frequency converter enclosure or motor terminal box
- No maintenance required





## Environmentally responsible

VLT® products are manufactured with respect for the safety and well-being of people and the environment.

All activities are planned and performed taking into account the individual employee, the work environment and the external environment. Production takes place with a minimum of noise, smoke or other pollution and environmentally safe disposal of the products is pre-prepared.

### UN Global Compact

Danfoss has signed the UN Global Compact on social and environmental responsibility and our companies act responsibly towards local societies.

### EU Directives

All factories are certified according to ISO 14001 standard. All products fulfil the EU Directives for General Product Safety and the Machinery directive. Danfoss VLT Drives is, in all product series, implementing the EU Directive concerning Hazardous Substances in Electrical and Electrical Equipment (RoHS) and is designing all new product series according to the EU Directive on Waste Electrical and Electronic Equipment (WEEE).

### Impact on energy savings

One year's energy savings from our annual production of VLT® drives will save the energy equivalent to the energy production from a major power plant. Better process control at the same time improves product quality and reduces waste and wear on equipment.

# What VLT® is all about

*Danfoss VLT Drives is the world leader among dedicated drives providers – and still gaining market share.*

### Dedicated to drives

Dedication has been a key word since 1968, when Danfoss introduced the world's first mass produced variable speed drive for AC motors – and named it VLT®.

Twenty five hundred employees develop, manufacture, sell and service drives and soft starters in more than one hundred countries, focused only on drives and soft starters.

### Intelligent and innovative

Developers at Danfoss VLT Drives have fully adopted modular principles in development as well as design, production and configuration.

Tomorrow's features are developed in parallel using dedicated technology platforms. This allows the development of all elements to take place in parallel, at the same time reducing time to market and ensuring that customers always enjoy the benefits of the latest features.

### Rely on the experts

We take responsibility for every element of our products. The fact that we develop and produce our own features, hardware, software, power modules, printed circuit boards, and accessories is your guarantee of reliable products.

### Local backup – globally

VLT® motor controllers are operating in applications all over the world and Danfoss VLT Drives' experts located in more than 100 countries are ready to support our customers with application advice and service wherever they may be.

Danfoss VLT Drives experts don't stop until the customer's drive challenges are solved.

